



## Standard Test Method for Static Puncture Strength of Geotextiles and Geotextile- Related Products Using a 50-mm Probe<sup>1</sup>

This standard is issued under the fixed designation D6241; the number immediately following the designation indicates the year of original adoption or, in the case of revision, the year of last revision. A number in parentheses indicates the year of last reapproval. A superscript epsilon ( $\epsilon$ ) indicates an editorial change since the last revision or reapproval.

### 1. Scope

1.1 This test method is an index test used to measure the force required to puncture a geotextile and geotextile-related products. The relatively large size of the plunger provides a multidirectional force on the geotextile.

1.2 The values stated in SI units are to be regarded as the standard. The values given in parentheses are for information only.

1.3 *This standard does not purport to address all of the safety concerns, if any, associated with its use. It is the responsibility of the user of this standard to establish appropriate safety and health practices and determine the applicability of regulatory limitations prior to use.*

### 2. Referenced Documents

2.1 *ASTM Standards:*<sup>2</sup>

[D76/D76M Specification for Tensile Testing Machines for Textiles](#)

[D123 Terminology Relating to Textiles](#)

[D1776 Practice for Conditioning and Testing Textiles](#)

[D1883 Test Method for CBR \(California Bearing Ratio\) of Laboratory-Compacted Soils](#)

[D4354 Practice for Sampling of Geosynthetics and Rolled Erosion Control Products \(RECPs\) for Testing](#)

[D4439 Terminology for Geosynthetics](#)

[E691 Practice for Conducting an Interlaboratory Study to Determine the Precision of a Test Method](#)

NOTE 1—Test Method [D1883](#) describes a mold (CBR mold) that can be used for this test method.

### 3. Terminology

3.1 *Definitions*—For definitions of other textile terms used in this test method, refer to Terminology [D123](#). For definitions

<sup>1</sup> This test method is under the jurisdiction of ASTM Committee D35 on Geosynthetics is the direct responsibility of Subcommittee D35.01 on Mechanical Properties

Current edition approved July 1, 2014. Published July 2014. Originally approved in 1998. Last previous edition approved in 2009 as D6241 – 04(2009)<sup>1</sup>. DOI: 10.1520/D6241-14.

<sup>2</sup> For referenced ASTM standards, visit the ASTM website, [www.astm.org](http://www.astm.org), or contact ASTM Customer Service at [service@astm.org](mailto:service@astm.org). For *Annual Book of ASTM Standards* volume information, refer to the standard's Document Summary page on the ASTM website.

of other terms relating to geosynthetics used in this test method, refer to Terminology [D4439](#).

3.2 *Definitions of Terms Specific to This Standard:*

3.2.1 *atmosphere for testing geotextiles, n*—air maintained at a relative humidity of 50 to 70 % and a temperature of  $21 \pm 2^\circ\text{C}$  ( $70 \pm 4^\circ\text{F}$ ).

3.2.2 *geotextile, n*—a permeable geosynthetic composed solely of textiles.

3.2.3 *puncture resistance, n*—the inherent resisting mechanism of the test specimen to the failure by a penetrating or puncturing object.

### 4. Summary of Test Method

4.1 A test specimen is clamped without tension between circular plates and secured in a tensile or compression testing machine, or both. A force is exerted against the center of the unsupported portion of the test specimen by a steel plunger attached to the load indicator until rupture occurs. The maximum force is the value of puncture strength.

### 5. Significance and Use

5.1 This test method for determining the puncture strength of geotextiles is to be used by the industry as an index of puncture strength. The use of this test method is to establish an index value by providing standard criteria and a basis for uniform reporting.

5.2 This test method is considered satisfactory for acceptance testing of commercial shipments of geotextiles.

5.3 In case of a dispute arising from differences in reported test results when using this test method for acceptance testing of commercial shipments, the purchaser and the supplier should conduct comparative tests to determine if there is a statistical bias between their laboratories. Competent statistical assistance is recommended for the investigation of bias. As a minimum, the two parties should take a group of test specimens that are as homogeneous as possible and that are from a lot of the type in question. The test specimens then should be randomly assigned in equal numbers to each laboratory for testing. The average results from the two laboratories should be compared using Student's t-test for unpaired data and an acceptable probability level chosen by the two parties before

the testing is begun. If a bias is found, either its cause must be found and corrected, or the purchaser and the supplier must agree to interpret future test results in the light of the known bias.

5.4 This test method is not applicable to materials that are manufactured in sizes that are too small to be placed into the test apparatus in accordance with the procedures in this test method. Furthermore, it is not appropriate to separate plies of a geosynthetic or geocomposite for use in this test method.

**6. Apparatus**

6.1 *Testing Machine*, must be constant-rate-of extension (CRE) type, with autographic recorder conforming to the requirement of Specification D76/D76M.

6.2 *Plunger*, with a flat diameter of  $50 \pm 1$  mm with a radial edge of  $2.5 \pm 0.5$  mm. See Fig. 1.

6.3 *Clamping Apparatus*, consisting of concentric plates with an internal diameter of 150 mm (5.9 in.), capable of clamping the test specimen without slippage (limit slippage of test specimen to 5 mm). The external diameter is suggested to be 250 mm (9.8 in.). The diameter of the holes used for

securing the ring clamp assemblage is suggested to be 11 mm (7/16 in.) and equally spaced at a diameter of 220 mm (8.7 in.). The surfaces of these plates can consist of grooves with rubber O-rings or coarse sandpaper bonded onto opposing surfaces. It is suggested that 9.5-mm (3/8-in.) bolts be welded to the bottom plate so that the top plate can be placed over the bolts and nuts easily tightened. A guide block may be used to help seat the material being clamped. Other clamps that eliminate slippage are acceptable. See Fig. 2 and Fig. 3.

**7. Sampling**

7.1 *Lot Sample*—In the absence of other guidelines, divide the product into lots and take lot samples as specified in Practice D4354.

7.2 *Laboratory Sample*—Consider the units in the lot sample as the units in the laboratory sample. For the laboratory sample, take a full width sample of sufficient length along the selvage or edge of the roll so that the requirements of 7.3 through 7.5.2 can be met. Exclude the inner and outer wraps of the roll or any material containing folds, crushed areas, or other distortions not representative of the sample lot.

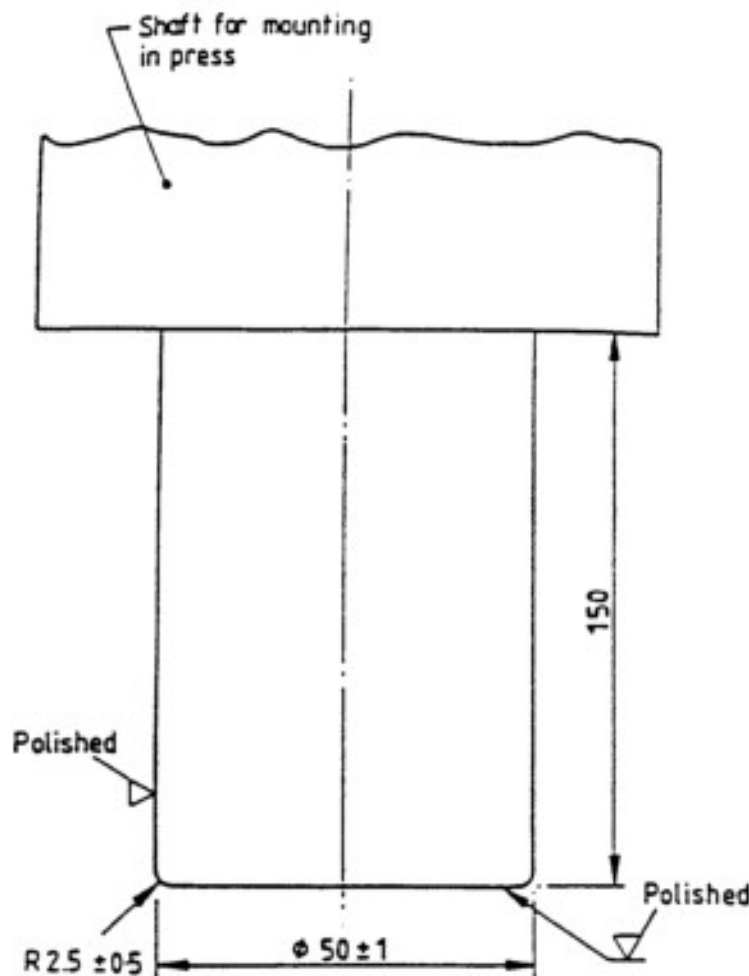

NOTE 1—All dimensions are in millimetres.  
NOTE 2—This diagram is not to scale.

FIG. 1 Plunger

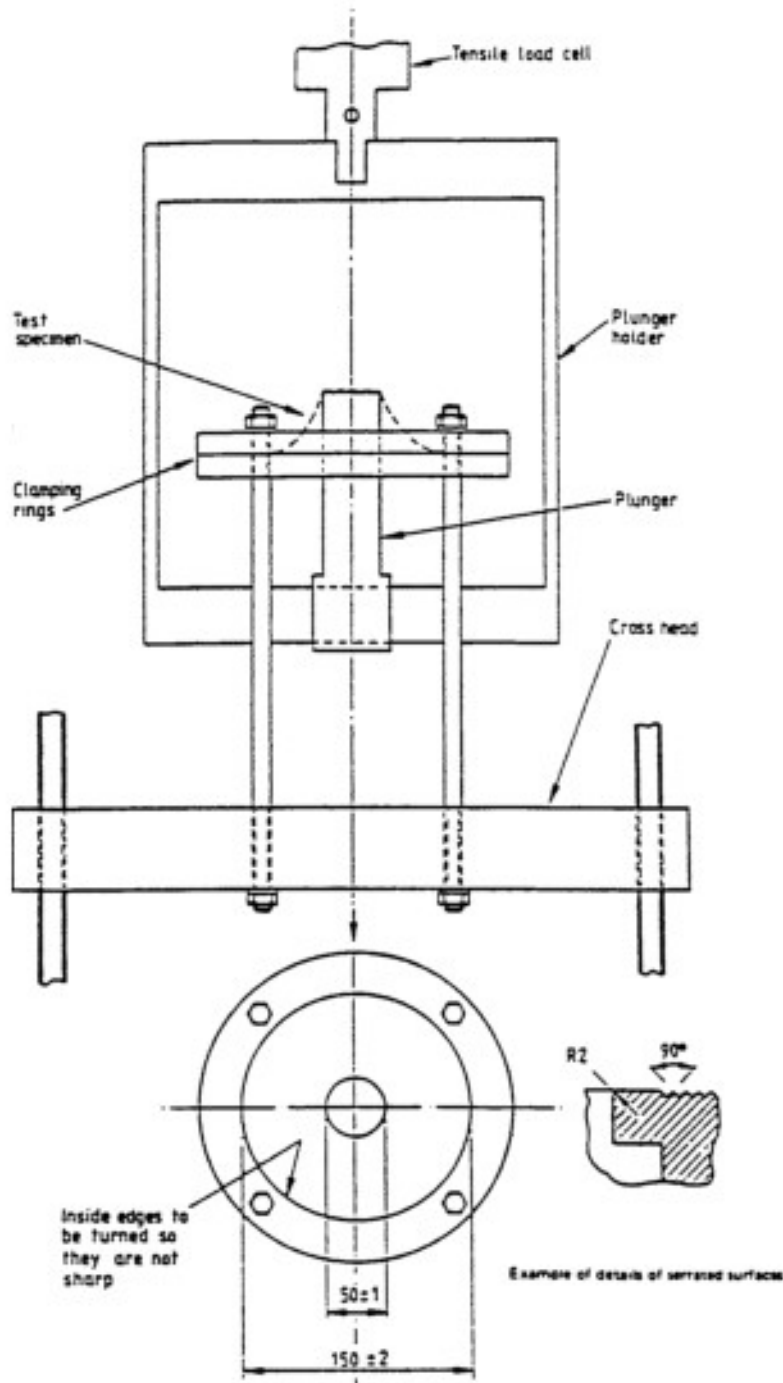

NOTE 1—All dimensions are in millimetres.

NOTE 2—This diagram is not to scale.

FIG. 2 Typical Arrangement for Test on Tensile Testing Machine (Method A)

7.3 Remove test specimens from the laboratory sample in a randomly distributed pattern across the width with no specimen taken nearer the selvage of fabric edge than 1/20 of the fabric width or 150 mm (6 in.), whichever is the smaller, unless otherwise specified.

7.4 *Test Specimens*—From each unit in the laboratory sample, cut the specimens so that the edge of specimen will extend beyond the edge of the clamp by 10 mm (0.39 in.) in all directions.

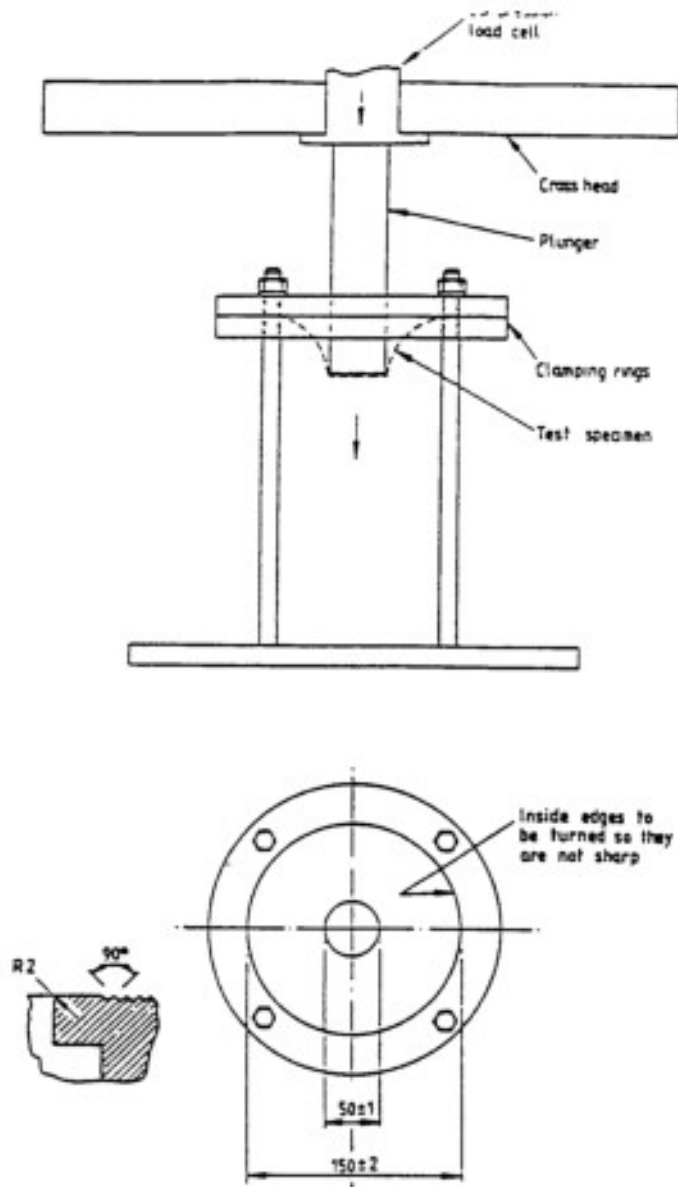

Example of detail of serrated surface

Note 1—All dimensions are in millimetres.

Note 2—The diagram is not to scale.

FIG. 3 Typical Arrangement for Test on Compression Testing Machine (Method B)

7.5 *Number of Specimens*—Unless otherwise agreed upon, as when provided in an applicable material specification, take a number of test specimens per laboratory sample such that the user may expect at the 95 % probability level that the test result is not more than 5.0 % of the average above or below the true average of sample. Determine the number of specimens per sample as follows:

7.5.1 *Reliable Estimate of  $v$* —When there is a reliable estimate of  $v$  based upon extensive past records for similar materials tested in the user's laboratory as directed in this test method, calculate the required number of specimens as follows:

$$n = (t/vA)^2 \quad (1)$$

where:

- $n$  = number of test specimens (rounded upward to a whole number),
- $v$  = reliable estimate of the coefficient of variation for individual observations on similar materials in the user's laboratory under conditions of single-operation precision, %,
- $t$  = the value of Student's  $t$  one-sided limits, a 95 % probability level, and the degrees of freedom, associated with the estimate of  $v$ , and



$A = 5.0\%$  of the average, the value of the allowable variation.

**7.5.2 No Reliable Estimate of  $v$** —When there is no reliable estimate of  $v$  for the user's laboratory, the equation given in 7.5.1 should not be used directly. Instead, specify the fixed number (10) of specimens. The number of specimens is calculated using  $v = 9.5\%$  of the average. These values for  $v$  are somewhat larger than usually found in practice. When a reliable estimate of  $v$  for the user's laboratory becomes available, the equation given in 7.5.1 usually will require fewer than the fixed number of specimens.

**NOTE 2**—If the material to be tested is known to have different characteristics on the two sides, for example, physical characteristics of as a consequence of the manufacturing process, then the complete test shall be carried out separately on each face.

## 8. Conditioning

8.1 Bring the specimens to moisture equilibrium in the atmosphere for testing geotextiles. Equilibrium is considered to have been reached when the increase in mass of the specimen in successive weightings made at intervals of not less than 2 h does not exceed 0.1 % of the mass of the specimen. In general practice, the industry approaches equilibrium from the "as received" side.

**NOTE 3**—It is recognized that in practice geotextiles materials frequently are not weighted to determine when moisture equilibrium has been reached. While such a procedure cannot be accepted in cases of dispute, it may be sufficient in routine testing to expose the material to the standard atmosphere for testing for a reasonable period of time before the specimens are tested. At least 24 h has been found acceptable in most cases. However, certain fibers may exhibit slow moisture equalization rates from the "as received" wet side. When this is known, a preconditioning cycle, as described in Practice D1776, may be agreed upon between contractual parties.

## 9. Procedure

9.1 Select the load range of the tensile testing machine such that the rupture occurs between 10 and 90 % of the full-scale load.

9.2 Center and secure the test specimen between the holding plates ensuring that the test specimen extends to or beyond the outer edges of the clamping plates.

9.3 Mark the test specimen along the inside circumference of the holding container. This allows for a measurement of potential slippage of the specimen.

9.4 If slippage greater than 5 mm is observed, the test on that specimen should be discarded and a new specimen should be obtained.

9.5 Test at a machine speed of 50 mm/min (approximately 2 in./min) until the puncture rod completely ruptures the test specimen. Read the puncture strength and displacement from the greatest force registered on the recording instrument during the test. For the testing of composite geotextiles, there may be a double peak. If so, the initial value should be reported even if the second peak is higher than the first one.

## 10. Calculation

10.1 Calculate the average of the puncture strength for all test results as read directly from the recording instrument.

## 11. Report

11.1 State that the material was tested in accordance with Test Method D6241. State the manner in which the specimens were conditioned. Describe the material or product sample and the method of sampling used.

11.2 Report the following information:

11.2.1 The method of holding the test specimen in the clamping device.

11.2.2 The average puncture strength of the specimens tested.

11.2.3 The variation of data within each group of specimens.

11.2.4 The variation, if any, from the described test method.

11.3 Upon request, the graph of plunger force versus displacement. A typical graph is given in Fig. 4.

## 12. Precision and Bias

12.1 Precision.

12.1.1 *Interlaboratory Testing Programs*—An interlaboratory testing program (ILS) was performed in 2003. The design of the experiment, similar to that of Practice E691. A 270-g/m<sup>2</sup> (8-oz/sy) needle-punched nonwoven geotextile and a 540-g/m<sup>2</sup> (16-oz/sy) needle-punched nonwoven geotextile were circulated to eight laboratories.

12.1.2 *Test Results*—The precision information is presented in Table 1 for the four materials. The average values listed for the strength test results are in units of N (lbs).

12.2 *Bias*—The procedure in this test method for measuring the static puncture strength of geotextiles using a 50-mm probe has no bias because the values of puncture strength can only be defined in terms of a test method.

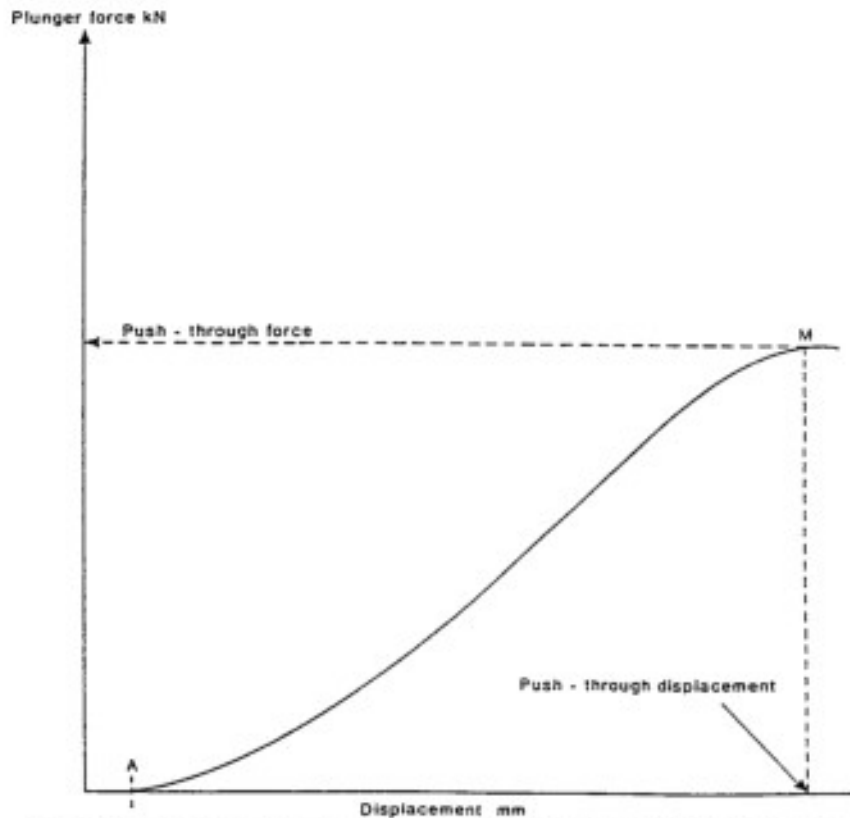

FIG. 4 Example of Typical Curve, Plunger Force Versus Plunger Displacement

TABLE 1 Precision

Material	Average Puncture Strength	95 % Confidence Repeatability Limit	95 % Confidence Reproducibility Limit
(8-oz/sy) Nonwoven Geotextile	3045 (684)	11.3	15.3
(18-oz/sy) Nonwoven Geotextile	7133 (1603)	10.3	15.4

ASTM International takes no position respecting the validity of any patent rights asserted in connection with any item mentioned in this standard. Users of this standard are expressly advised that determination of the validity of any such patent rights, and the risk of infringement of such rights, are entirely their own responsibility.

This standard is subject to revision at any time by the responsible technical committee and must be reviewed every five years and if not revised, either reapproved or withdrawn. Your comments are invited either for revision of this standard or for additional standards and should be addressed to ASTM International Headquarters. Your comments will receive careful consideration at a meeting of the responsible technical committee, which you may attend. If you feel that your comments have not received a fair hearing you should make your views known to the ASTM Committee on Standards, at the address shown below.

This standard is copyrighted by ASTM International, 100 Barr Harbor Drive, PO Box C700, West Conshohocken, PA 19428-2959, United States. Individual reprints (single or multiple copies) of this standard may be obtained by contacting ASTM at the above address or at 610-832-9585 (phone), 610-832-9555 (fax), or service@astm.org (e-mail); or through the ASTM website (www.astm.org). Permission rights to photocopy the standard may also be secured from the Copyright Clearance Center, 222 Rosewood Drive, Danvers, MA 01923. Tel: (978) 646-2600; <http://www.copyright.com/>