



ASTM D1414 Motorized O-ring Fixture



Tensile Rating: 2kN (450 lbs.)

Adjustable Speed: 4-17 RPM

Power supply: 220V converting to 12V, 1A – US + International plugs available

Weight: 2kg

Temperature Range: 0 to 50 Celsius

Adapter/Coupling: female 5/8" with 5/16" locking pin

Scope of Delivery: Bottom, Top, Power supply, 2 roller sizes – 15mm + 25mm

Schematic (mm)

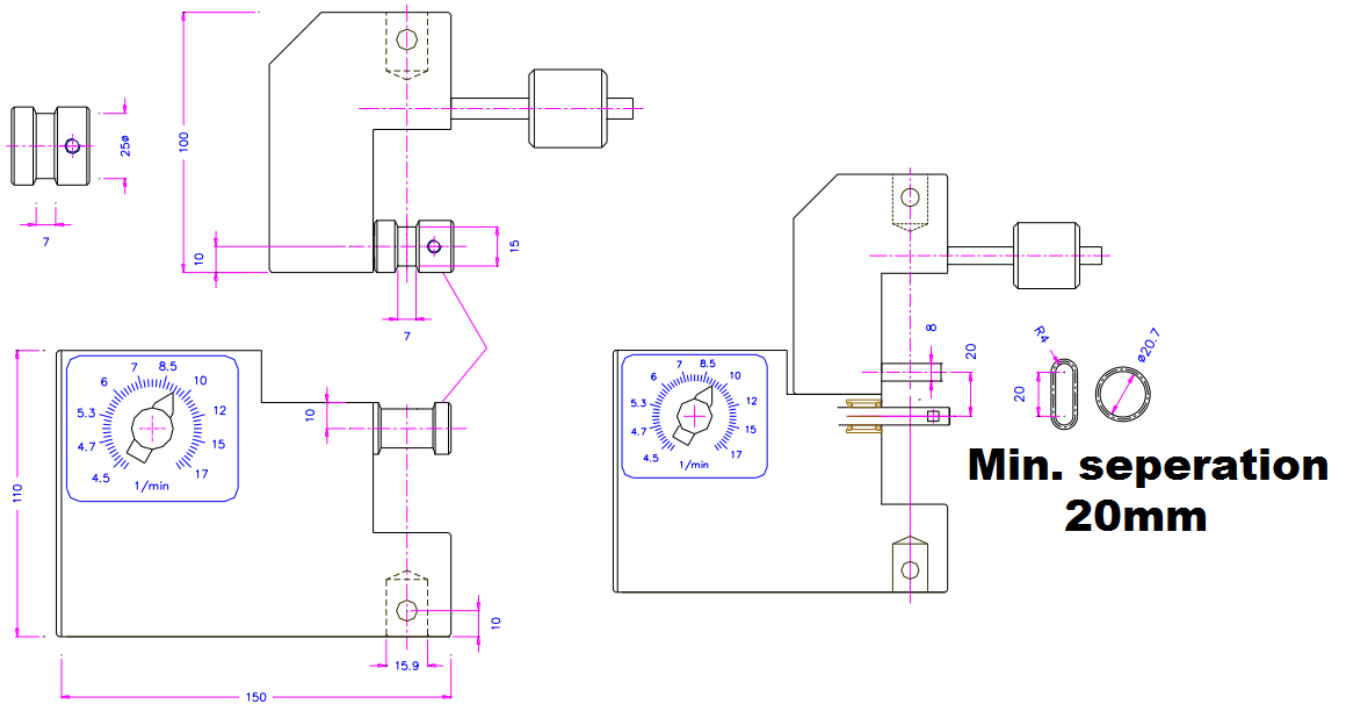

- 3.18
- 4.5
- 4.75
- 6.35
- 12.7
- 15
- 18.3
- 22.3
- 25

**Choose
Diameter
Inserts
(mm)**

Special Setup for Small O-rings

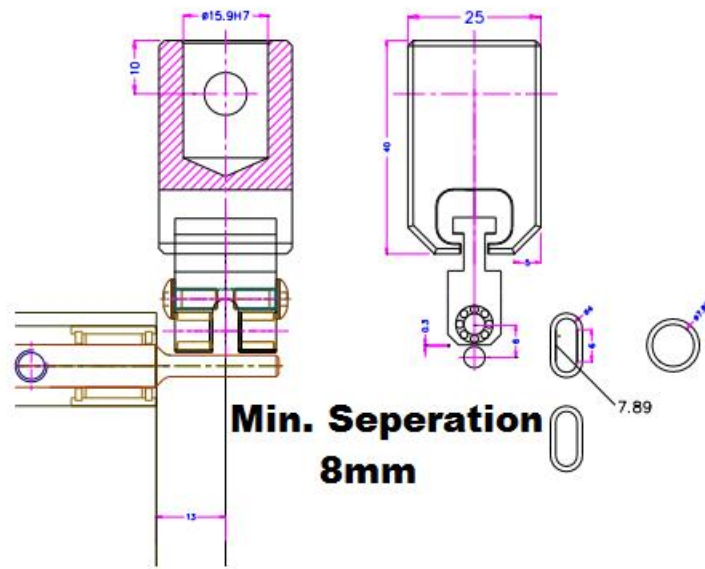



Low Cost Non-Motorized Fixture

