



# Standard Test Methods of Static Tests of Lumber in Structural Sizes<sup>1</sup>

This standard is issued under the fixed designation D198; the number immediately following the designation indicates the year of original adoption or, in the case of revision, the year of last revision. A number in parentheses indicates the year of last reapproval. A superscript epsilon ( $\epsilon$ ) indicates an editorial change since the last revision or reapproval.

## INTRODUCTION

Numerous evaluations of structural members of sawn lumber have been conducted in accordance with Test Methods D198. While the importance of continued use of a satisfactory standard should not be underestimated, the original standard (1927) was designed primarily for sawn lumber material, such as bridge stringers and joists. With the advent of structural glued laminated (glulam) timbers, structural composite lumber, prefabricated wood I-joists, and even reinforced and prestressed timbers, a procedure adaptable to a wider variety of wood structural members was required and Test Methods D198 has been continuously updated to reflect modern usage.

The present standard provides a means to evaluate the flexure, compression, tension, and torsion strength and stiffness of lumber and wood-based products in structural sizes. A flexural test to evaluate the shear stiffness is also provided. In general, the goal of the D198 test methods is to provide a reliable and repeatable means to conduct laboratory tests to evaluate the mechanical performance of wood-based products. While many of the properties tested using these methods may also be evaluated using the field procedures of Test Methods D4761, the more detailed D198 test methods are intended to establish practices that permit correlation of results from different sources through the use of more uniform procedures. The D198 test methods are intended for use in scientific studies, development of design values, quality assurance, or other investigations where a more accurate test method is desired. Provision is made for varying the procedure to account for special problems.

## 1. Scope

1.1 These test methods cover the evaluation of lumber and wood-based products in structural sizes by various testing procedures.

1.2 The test methods appear in the following order:

	Sections
Flexure	4 – 11
Compression (Short Specimen)	13 – 20
Compression (Long Specimen)	21 – 28
Tension	29 – 36
Torsion	37 – 44
Shear Modulus	45 – 52

1.3 Notations and symbols relating to the various testing procedures are given in [Appendix X1](#).

1.4 The values stated in inch-pound units are to be regarded as standard. The values given in parentheses are mathematical conversions to SI units that are provided for information only and are not considered standard.

1.5 *This standard does not purport to address all of the safety concerns, if any, associated with its use. It is the responsibility of the user of this standard to establish appropriate safety and health practices and determine the applicability of regulatory limitations prior to use.*

## 2. Referenced Documents

2.1 *ASTM Standards:*<sup>2</sup>

[D9 Terminology Relating to Wood and Wood-Based Products](#)

[D1165 Nomenclature of Commercial Hardwoods and Softwoods](#)

[D2395 Test Methods for Density and Specific Gravity \(Relative Density\) of Wood and Wood-Based Materials](#)

[D2915 Practice for Sampling and Data-Analysis for Structural Wood and Wood-Based Products](#)

[D3737 Practice for Establishing Allowable Properties for Structural Glued Laminated Timber \(Glulam\)](#)

[D4442 Test Methods for Direct Moisture Content Measurement of Wood and Wood-Based Materials](#)

<sup>1</sup> These test methods are under the jurisdiction of ASTM Committee D07 on Wood and are the direct responsibility of Subcommittee D07.01 on Fundamental Test Methods and Properties.

Current edition approved Sept. 1, 2015. Published December 2015. Originally approved in 1924. Last previous edition approved in 2014 as D198–14<sup>ε1</sup>. DOI: 10.1520/D0198-15.

<sup>2</sup> For referenced ASTM standards, visit the ASTM website, [www.astm.org](http://www.astm.org), or contact ASTM Customer Service at [service@astm.org](mailto:service@astm.org). For *Annual Book of ASTM Standards* volume information, refer to the standard's Document Summary page on the ASTM website.

- D4761 Test Methods for Mechanical Properties of Lumber and Wood-Base Structural Material
- D7438 Practice for Field Calibration and Application of Hand-Held Moisture Meters
- E4 Practices for Force Verification of Testing Machines
- E6 Terminology Relating to Methods of Mechanical Testing
- E83 Practice for Verification and Classification of Extensometer Systems
- E177 Practice for Use of the Terms Precision and Bias in ASTM Test Methods
- E691 Practice for Conducting an Interlaboratory Study to Determine the Precision of a Test Method
- E2309 Practices for Verification of Displacement Measuring Systems and Devices Used in Material Testing Machines

product for which strength or stiffness, or both, are primary criteria for the intended application and which usually are used in full length and in cross-sectional sizes greater than nominal 2 by 2 in. (38 by 38 mm).

**FLEXURE**

**4. Scope**

4.1 This test method covers the determination of the flexural properties of structural members. This test method is intended primarily for members with rectangular cross sections but is also applicable to members with round and irregular shapes, such as round posts, pre-fabricated wood I-joists, or other special sections.

**5. Summary of Test Method**

5.1 The flexure specimen is subjected to a bending moment by supporting it near its ends, at locations called reactions, and applying transverse loads symmetrically imposed between these reactions. The specimen is deflected at a prescribed rate, and coordinated observations of loads and deflections are made until rupture occurs.

**6. Significance and Use**

- 6.1 The flexural properties established by this test method provide:
- 6.1.1 Data for use in development of grading rules and specifications;
  - 6.1.2 Data for use in development of design values for structural members;
  - 6.1.3 Data on the influence of imperfections on mechanical properties of structural members;
  - 6.1.4 Data on strength properties of different species or grades in various structural sizes;
  - 6.1.5 Data for use in checking existing equations or hypotheses relating to the structural behavior;
  - 6.1.6 Data on the effects of chemical or environmental conditions on mechanical properties;
  - 6.1.7 Data on effects of fabrication variables such as depth, taper, notches, or type of end joint in laminations; and
  - 6.1.8 Data on relationships between mechanical and physical properties.

**3. Terminology**

3.1 *Definitions*—See Terminology E6, Terminology D9, and Nomenclature D1165.

3.2 *Definitions: Definitions of Terms Specific to This Standard:*

3.2.1 *composite wood member*—a laminar construction comprising a combination of wood and other simple or complex materials assembled and intimately fixed in relation to each other so as to use the properties of each to attain specific structural advantage for the whole assembly.

3.2.2 *depth (d)*—the dimension of the flexure specimen or shear modulus specimen that is perpendicular to the span and parallel to the direction in which the load is applied (Fig. 1).

3.2.3 *shear span*—two times the distance between a reaction and the nearest load point for a symmetrically loaded flexure specimen (Fig. 1).

3.2.4 *shear span-depth ratio*—the numerical ratio of shear span divided by depth of a flexure specimen.

3.2.5 *span (ℓ)*—the total distance between reactions on which a flexure specimen or shear modulus specimen is supported to accommodate a transverse load (Fig. 1).

3.2.6 *span-depth ratio (ℓ/d)*—the numerical ratio of total span divided by depth of a flexure specimen or shear modulus specimen.

3.2.7 *structural member*—sawn lumber, glulam, structural composite lumber, prefabricated wood I-joists, or other similar

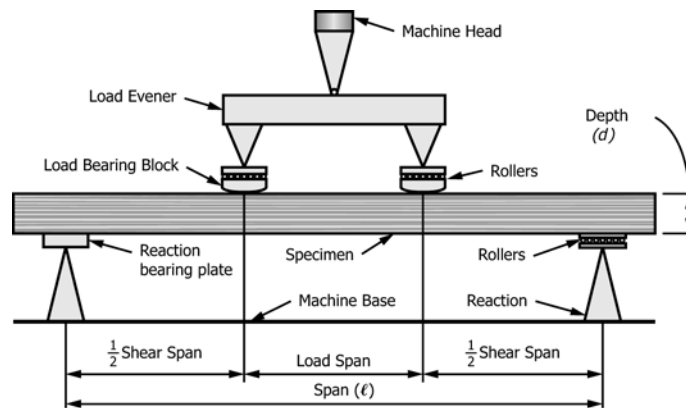

**FIG. 1 Flexure Test Method—Example of Two-Point Loading**

6.2 Procedures are described here in sufficient detail to permit duplication in different laboratories so that comparisons of results from different sources will be valid. Where special circumstances require deviation from some details of these procedures, these deviations shall be carefully described in the report (see Section 11).

## 7. Apparatus

7.1 *Testing Machine*—A device that provides (1) a rigid frame to support the specimen yet permit its deflection without restraint, (2) a loading head through which the force is applied without high-stress concentrations in the specimen, and (3) a force-measuring device that is calibrated to ensure accuracy in accordance with Practices E4.

7.2 *Support Apparatus*—Devices that provide support of the specimen at the specified span.

7.2.1 *Reaction Bearing Plates*—The specimen shall be supported by metal bearing plates to prevent damage to the specimen at the point of contact with the reaction support (Fig. 1). The plates shall be of sufficient length, thickness, and width to provide a firm bearing surface and ensure a uniform bearing stress across the width of the specimen.

7.2.2 *Reaction Supports*—The bearing plates shall be supported by devices that provide unrestricted longitudinal deformation and rotation of the specimen at the reactions due to loading. Provisions shall be made to restrict horizontal translation of the specimen (see 7.3.1 and Appendix X5).

7.2.3 *Reaction Bearing Alignment*—Provisions shall be made at the reaction supports to allow for initial twist in the length of the specimen. If the bearing surfaces of the specimen at its reactions are not parallel, then the specimen shall be shimmed or the individual bearing plates shall be rotated about an axis parallel to the span to provide full bearing across the width of the specimen. Supports with lateral self-alignment are normally used (Fig. 2).

7.2.4 *Lateral Support*—Specimens that have a depth-to-width ratio ( $d/b$ ) of three or greater are subject to out-of-plane lateral instability during loading and require lateral support. Lateral support shall be provided at points located about halfway between a reaction and a load point. Additional supports shall be permitted as required to prevent lateral-torsional buckling. Each support shall allow vertical movement without frictional restraint but shall restrict lateral displacement (Fig. 3).

7.3 *Load Apparatus*—Devices that transfer load from the testing machine at designated points on the specimen. Provisions shall be made to prevent eccentric loading of the load measuring device (see Appendix X5).

7.3.1 *Load Bearing Blocks*—The load shall be applied through bearing blocks (Fig. 1), which are of sufficient thickness and extending entirely across the specimen width to eliminate high-stress concentrations at places of contact between the specimen and bearing blocks. Load shall be applied to the blocks in such a manner that the blocks shall be permitted to rotate about an axis perpendicular to the span (Fig. 4). To prevent specimen deflection without restraint in case of two-point loading, metal bearing plates and rollers shall be used in conjunction with one or both load-bearing blocks,

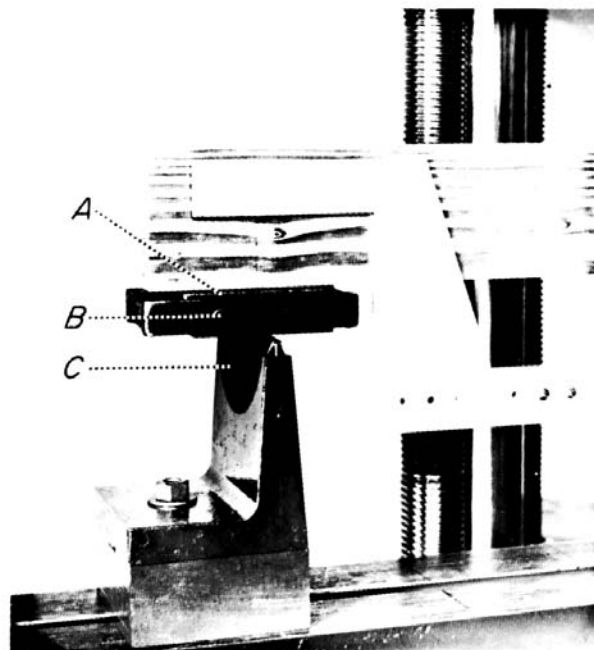

FIG. 2 Example of Bearing Plate (A), Rollers (B), and Reaction-Alignment-Rocker (C), for Small Flexure Specimens

depending on the reaction support conditions (see Appendix X5). Provisions such as rotatable bearings or shims shall be made to ensure full contact between the specimen and the loading blocks. The size and shape of these loading blocks, plates, and rollers may vary with the size and shape of the specimen, as well as for the reaction bearing plates and supports. For rectangular structural products, the loading surface of the blocks shall have a radius of curvature equal to two to four times the specimen depth. Specimens having circular or irregular cross-sections shall have bearing blocks that distribute the load uniformly to the bearing surface and permit unrestrained deflections.

7.3.2 *Load Points*—Location of load points relative to the reactions depends on the purpose of testing and shall be recorded (see Appendix X5).

7.3.2.1 *Two-Point Loading*—The total load on the specimen shall be applied equally at two points equidistant from the reactions. The two load points will normally be at a distance from their reaction equal to one third of the span ( $\ell/3$ ) (third-point loading), but other distances shall be permitted for special purposes.

7.3.2.2 *Center-Point Loading*—A single load shall be applied at mid-span.

7.3.2.3 For evaluation of shear properties, center-point loading or two-point loading shall be used (see Appendix X5).

### 7.4 Deflection-Measuring Apparatus:

7.4.1 *General*—For modulus of elasticity calculations, devices shall be provided by which the deflection of the neutral axis of the specimen at the center of the span is measured with respect to a straight line joining two reference points equidistant from the reactions and on the neutral axis of the specimen.

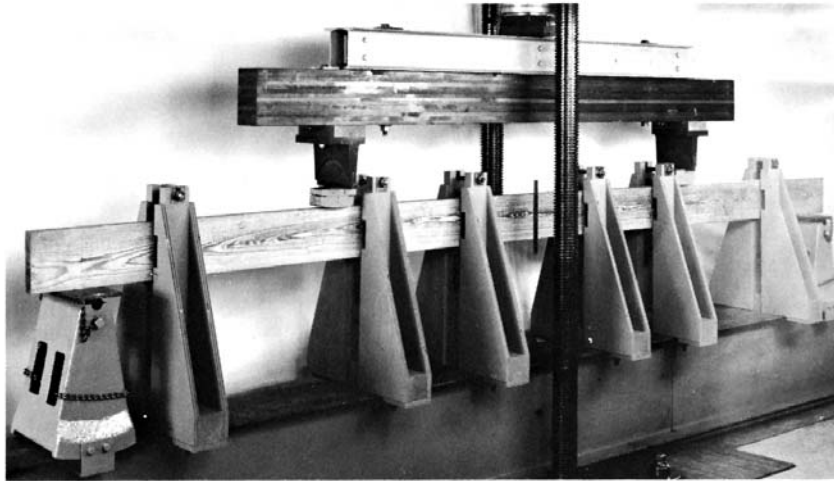

FIG. 3 Example of Lateral Support for Long, Deep Flexure Specimens

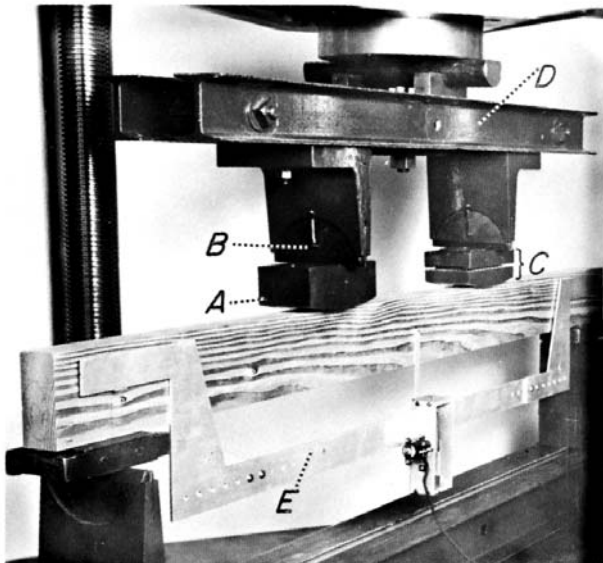

FIG. 4 Example of Curved Loading Block (A), Load-Alignment Rocker (B), Roller-Curved Loading Block (C), Load Evener (D), and Deflection-Measuring Apparatus (E)

7.4.2 *Wire Deflectometer*—A wire stretched taut between two nails, smooth dowels, or other rounded fixtures attached to the neutral axis of the specimen directly above the reactions and extending across a scale attached at the neutral axis of the specimen at mid-span shall be permitted to read deflections with a telescope or reading glass to magnify the area where the wire crosses the scale. When a reading glass is used, a reflective surface placed adjacent to the scale will help to avoid parallax.

7.4.3 *Yoke Deflectometer*—A satisfactory device commonly used to measure deflection of the center of the specimen with respect to any point along the neutral axis consists of a lightweight U-shaped yoke suspended between nails, smooth dowels, or other rounded fixtures attached to the specimen at its neutral axis. An electronic displacement gauge, dial micrometer, or other suitable measurement device attached to the center of the yoke shall be used to measure vertical displacement at mid-span relative to the specimen's neutral axis (Fig. 4).

7.4.4 *Alternative Deflectometers*—Deflectometers that do not conform to the general requirements of 7.4.1 shall be permitted provided the mean deflection measurements are not significantly different from those devices conforming to 7.4.1. The equivalency of such devices to deflectometers, such as those described in 7.4.2 or 7.4.3, shall be documented and demonstrated by comparison testing.

NOTE 2—Where possible, equivalency testing should be undertaken in the same type of product and stiffness range for which the device will be used. Issues that should be considered in the equivalency testing include the effect of crushing at and in the vicinity of the load and reaction points, twist in the specimen, and natural variation in properties within a specimen.

7.4.5 *Accuracy*—The deflection measurement devices and recording system shall be capable of at least a Class B rating when evaluated in accordance with Practice E2309.

## 8. Flexure Specimen

8.1 *Material*—The flexure specimen shall consist of a structural member.

7.4.1.1 The apparent modulus of elasticity ( $E_{app}$ ) shall be calculated using the full-span deflection ( $\Delta$ ). The reference points for the full-span deflection measurements shall be positioned such that a line perpendicular to the neutral axis at the location of the reference point, passes through the support's center of rotation.

7.4.1.2 The true or shear-free modulus of elasticity ( $E_{sf}$ ) shall be calculated using the shear-free deflection. The reference points for the shear-free deflection measurements shall be positioned at cross-sections free of shear and stress concentrations (see Appendix X5).

NOTE 1—The apparent modulus of elasticity ( $E_{app}$ ) may be converted to the shear-free modulus of elasticity ( $E_{sf}$ ) by calculation, assuming that the shear modulus ( $G$ ) is known. See Appendix X2.



**8.2 Identification**—Material or materials of the specimen shall be identified as fully as possible by including the origin or source of supply, species, and history of drying and conditioning, chemical treatment, fabrication, and other pertinent physical or mechanical details that potentially affect the strength or stiffness. Details of this information shall depend on the material or materials in the structural member. For example, wood beams or joists would be identified by the character of the wood, that is, species, source, and so forth, whereas structural composite lumber would be identified by the grade, species, and source of the material (that is, product manufacturer, manufacturing facility, etc.).

**8.3 Specimen Measurements**—The weight and dimensions (length and cross-section) of the specimen shall be measured before the test to three significant figures. Sufficient measurements of the cross section shall be made along the length to describe the width and depth of rectangular specimens and to determine the critical section or sections of non-uniform (or non-prismatic) specimens. The physical characteristics of the specimen as described by its density or specific gravity shall be permitted to be determined in accordance with Test Methods [D2395](#).

**8.4 Specimen Description**—The inherent imperfections or intentional modifications of the composition of the specimen shall be fully described by recording the size and location of such factors as knots, checks, and reinforcements. Size and location of intentional modifications such as placement of laminations, glued joints, and reinforcing steel shall be recorded during the fabrication process. The size and location of imperfections in the interior of any specimen must be deduced from those on the surface, especially in the case of large sawn members. A sketch or photographic record shall be made of each face and the ends showing the size, location, and type of growth characteristics, including slope of grain, knots, distribution of sapwood and heartwood, location of pitch pockets, direction of annual rings, and such abstract factors as crook, bow, cup, or twist, which might affect the flexural strength.

**8.5 Rules for Determination of Specimen Length**—The cross-sectional dimensions of structural products usually have established sizes, depending upon the manufacturing process and intended use, so that no modification of these dimensions is involved. The length, however, will be established by the type of data desired (see [Appendix X5](#)). The span length is determined from knowledge of specimen depth, the distance between load points, as well as the type and orientation of material in the specimen. The total specimen length includes the span (measured from center to center of the reaction supports) and the length of the overhangs (measured from the center of the reaction supports to the ends of the specimen). Sufficient length shall be provided so that the specimen can accommodate the bearing plates and rollers and will not slip off the reactions during test.

**8.5.1** For evaluation of shear properties, the overhang beyond the span shall be minimized, as the shear capacity may be influenced by the length of the overhang. The reaction bearing plates shall be the minimum length necessary to prevent bearing failures. The specimen shall not extend beyond the end

of the reaction plates ([Fig. X5.3](#) in [Appendix X5](#)) unless longer overhangs are required to simulate a specific design condition.

## 9. Procedure

**9.1 Conditioning**—Unless otherwise indicated in the research program or material specification, condition the specimen to constant weight so it is in moisture equilibrium under the desired environmental conditions. Approximate moisture contents with moisture meters or measure more accurately by weights of samples in accordance with Test Methods [D4442](#).

**9.2 Test Setup**—Determine the size of the specimen, the span, and the shear span in accordance with [7.3.2](#) and [8.5](#). Locate the flexure specimen symmetrically on its supports with load bearing and reaction bearing blocks as described in [7.2 – 7.4](#). The specimen shall be adequately supported laterally in accordance with [7.2.4](#). Set apparatus for measuring deflections in place (see [7.4](#)). Full contact shall be attained between support bearings, loading blocks, and the specimen surface.

**9.3 Speed of Testing**—The loading shall progress at a constant deformation rate such that the average time to maximum load for the test series shall be at least 4 min. It is permissible to initially test a few random specimens from a series at an alternate rate as the test rate is refined. Otherwise, the selected rate shall be held constant for the test series.

### 9.4 Load-Deflection Curves:

**9.4.1** Obtain load-deflection data with apparatus described in [7.4.1](#). Note the load and deflection at first failure, at the maximum load, and at points of sudden change. Continue loading until complete failure or an arbitrary terminal load has been reached.

**9.4.2** If an additional deflection measuring apparatus is provided to measure the shear-free deflection ( $\Delta_{sf}$ ) over a second distance ( $\ell_{sf}$ ) in accordance with [7.4.1.2](#), such load-deflection data shall be obtained only up to the proportional limit.

**9.5 Record of Failures**—Describe failures in detail as to type, manner, and order of occurrence, and position in the specimen. Record descriptions of the failures and relate them to specimen drawings or photographs referred to in [8.4](#). Also record notations as the order of their occurrence on such references. Hold the section of the specimen containing the failure for examination and reference until analysis of the data has been completed.

**9.6 Moisture Content Determination**—Following the test, measure the moisture content of the specimen at a location away from the end and as close to the failure zone as practical in accordance with the procedures outlined in Test Methods [D4442](#). Alternatively, the moisture content for a wood specimen shall be permitted to be determined using a calibrated moisture meter according to Standard Practice [D7438](#). The number of moisture content samples shall be determined using Practice [D7438](#) guidelines, with consideration of the expected moisture content variability, and any related requirements in the referenced product standards.

## 10. Calculation

10.1 Compute physical and mechanical properties and their appropriate adjustments for the specimen in accordance with the relationships in [Appendix X2](#).

## 11. Report

11.1 Report the following information:

11.1.1 Complete identification of the specimen, including species, origin, shape and form, fabrication procedure, type and location of imperfections or reinforcements, and pertinent physical or chemical characteristics relating to the quality of the material,

11.1.2 History of seasoning and conditioning,

11.1.3 Loading conditions to portray the load and support mechanics, including type of equipment, lateral supports, if used, the location of load points relative to the reactions, the size of load bearing blocks, reaction bearing plates, clear distances between load block and reaction plate and between load blocks, and the size of overhangs, if present,

11.1.4 Deflection apparatus,

11.1.5 Depth and width of the specimen or pertinent cross-sectional dimensions,

11.1.6 Span length and shear span distance,

11.1.7 Rate of load application,

11.1.8 Computed physical and mechanical properties, including specific gravity or density (as applicable) and moisture content, flexural strength, stress at proportional limit, modulus of elasticity, calculation methods ([Note 3](#)), and a statistical measure of variability of these values,

**NOTE 3**—[Appendix X2](#) provides acceptable formulae and guidance for determining the flexural properties.

11.1.9 Description of failure, and

11.1.10 Details of any deviations from the prescribed or recommended methods as outlined in the standard.

## 12. Precision and Bias

12.1 *Interlaboratory Test Program*—An interlaboratory study (ILS) was conducted in 2006–2007 by sixteen laboratories in the United States and Canada in accordance with Practice [E691](#).<sup>3</sup> The scope of this study was limited to the determination of the apparent modulus of elasticity of three different 2 × 4 nominal sized products tested both edgewise and flatwise. The deflection of each flexure specimen's neutral axis at the mid-span was measured with a yoke according to [7.4](#). Five specimens of each product were tested in a round-robin fashion in each laboratory, with four test results obtained for each specimen and test orientation. The resulting precision indexes are shown in [Table 1](#). For further discussion, see [Appendix X5.4](#).

12.2 The terms of repeatability and reproducibility are used as specified in Practice [E177](#).

12.3 *Bias*—The bias is not determined because the apparent modulus of elasticity is defined in terms of this method, which is generally accepted as a reference ([Note 4](#)).

**NOTE 4**—Use of this method does not necessarily eliminate laboratory bias or ensure a level of consistency necessary for establishing reference values. The users are encouraged to participate in relevant interlaboratory studies (that is, an ILS involving sizes and types of product similar to those regularly tested by the laboratory) to provide evidence that their implementation of the Test Method provides levels of repeatability and

<sup>3</sup> Supporting data have been filed at ASTM International Headquarters and may be obtained by requesting Research Report RR: RR:D07-1005. Contact ASTM Customer Service at [service@astm.org](mailto:service@astm.org).

**TABLE 1 Test Materials, Configurations, and Precision Indexes<sup>A</sup>**

Product	Test Orientation	Width × Depth <i>b</i> × <i>d</i> in. (mm)	Span Test <i>ℓ</i> in. (mm)	Average Apparent Modulus of Elasticity <i>E<sub>app</sub></i> psi × 10 <sup>6</sup> (GPa)	Repeatability		Reproducibility		Repeatability		Reproducibility	
					Coefficient of Variation <i>CV<sub>r</sub></i>		Coefficient of Variation <i>CV<sub>R</sub></i>		Limits		Limits	
									<i>2CV<sub>r</sub></i>	<i>d2CV<sub>r</sub></i>	<i>2CV<sub>R</sub></i>	<i>d2CV<sub>R</sub></i>
A	Edgewise	1.5 × 3.5 (38 × 89)	63.0 (1600)	2.17 (14.9)	1.4 %		2.0 %		2.7 %	3.8 %	4.0 %	5.6 %
	Flatwise	3.5 × 1.5 (89 × 38)	31.5 (800)	2.18 (15.0)	1.4 %		3.3 %		2.7 %	3.9 %	6.5 %	9.2 %
B	Edgewise	1.5 × 3.5 (38 × 89)	63.0 (1600)	1.49 (10.3)	1.0 %		2.1 %		2.0 %	2.8 %	4.2 %	5.9 %
	Flatwise	3.5 × 1.5 (89 × 38)	31.5 (800)	1.54 (10.6)	1.3 %		2.7 %		2.6 %	3.6 %	5.3 %	7.5 %
C	Edgewise	1.5 × 3.5 (38 × 89)	63.0 (1600)	2.35 (16.2)	1.3 %		2.0 %		2.5 %	3.5 %	3.9 %	5.5 %
	Flatwise	3.5 × 1.5 (89 × 38)	31.5 (800)	2.78 (19.2)	1.5 %		4.3 %		2.9 %	4.2 %	8.3 %	11.8 %
All Data	Edgewise	1.5 × 3.5 (38 × 89)	63.0 (1600)	...	1.2 %		2.1 %		2.4 %	3.4 %	4.0 %	5.7 %
	Flatwise	3.5 × 1.5 (89 × 38)	31.5 (800)	...	1.4 %		3.4 %		2.7 %	3.9 %	6.7 %	9.5 %

<sup>A</sup> The precision indexes are the average values of five specimens tested in eleven laboratories which were found to be in statistical control and in compliance with the standard requirements.

reproducibility at least comparable to those shown in [Table 1](#). See also [X5.4.2](#) and [X5.4.3](#).

## COMPRESSION PARALLEL TO GRAIN (SHORT SPECIMEN, NO LATERAL SUPPORT, $\ell/r < 17$ )

### 13. Scope

13.1 This test method covers the determination of the compressive properties of specimens taken from structural members when such a specimen has a slenderness ratio (length to least radius of gyration) of less than 17. The method is intended primarily for structural members with rectangular cross sections, but is also applicable to irregularly shaped studs, braces, chords, round poles, or special sections.

### 14. Summary of Test Method

14.1 The specimen is subjected to a force uniformly distributed on the contact surface in a direction generally parallel to the longitudinal axis of the wood fibers, and the force generally is uniformly distributed throughout the specimen during loading to failure without flexure along its length.

### 15. Significance and Use

15.1 The compressive properties obtained by axial compression will provide information similar to that stipulated for flexural properties in [Section 6](#).

15.2 The compressive properties parallel to grain include modulus of elasticity ( $E_{axial}$ ), stress at proportional limit, compressive strength, and strain data beyond proportional limit.

### 16. Apparatus

16.1 *Testing Machine*—Any device having the following is suitable:

16.1.1 *Drive Mechanism*—A drive mechanism for imparting to a movable loading head a uniform, controlled velocity with respect to the stationary base.

16.1.2 *Load Indicator*—A load-indicating mechanism capable of showing the total compressive force on the specimen. This force-measuring system shall be calibrated to ensure accuracy in accordance with [Practices E4](#).

16.2 *Bearing Blocks*—Bearing blocks shall be used to apply the load uniformly over the two contact surfaces and to prevent eccentric loading on the specimen. At least one spherical bearing block shall be used to ensure uniform bearing. Spherical bearing blocks may be used on either or both ends of the specimen, depending on the degree of parallelism of bearing surfaces ([Fig. 5](#)). The radius of the sphere shall be as small as practicable, in order to facilitate adjustment of the bearing plate to the specimen, and yet large enough to provide adequate spherical bearing area. This radius is usually one to two times the greatest cross-section dimension. The center of the sphere shall be on the plane of the specimen contact surface. The size of the compression plate shall be larger than the contact surface. It has been found convenient to provide an adjustment for moving the specimen on its bearing plate with respect to the center of spherical rotation to ensure axial loading.

16.3 *Compressometer*:



**FIG. 5 Example Test Setup for a Short Specimen Compression Parallel to Grain Test (Two Bearing Blocks Illustrated)**

16.3.1 *Gauge Length*—For modulus of elasticity calculations, a device shall be provided by which the deformation of the specimen is measured with respect to specific paired gauge points defining the gauge length. To obtain test data representative of the test material as a whole, such paired gauge points shall be located symmetrically on the lengthwise surface of the specimen as far apart as feasible, yet at least one times the larger cross-sectional dimension from each of the contact surfaces. At least two pairs of such gauge points on the opposite sides of the specimen shall be used to measure the average deformation.

16.3.2 *Accuracy*—The device shall be able to measure changes in deformation to three significant figures. Since gauge lengths vary over a wide range, the measuring instruments should conform to their appropriate class in accordance with [Practice E83](#).

### 17. Compression Specimen

17.1 *Material*—The test specimen shall consist of a structural member that is greater than nominal 2 by 2-in. (38 by 38-mm) in cross section (see [3.2.7](#)).

17.2 *Identification*—Material or materials of the specimen shall be as fully described as for flexure specimens in [8.2](#).

17.3 *Specimen Measurements*—The weight and dimensions (length and cross-section) of the specimen, shall be measured

before the test to three significant figures. Sufficient measurements of the cross section shall be made along the length of the specimen to describe shape characteristics and to determine the smallest section. The physical characteristics of the specimen, as described by its density or specific gravity, shall be permitted to be determined in accordance with Test Method **D2395**.

**17.4 Specimen Description**—The inherent imperfections and intentional modifications shall be described as for flexure specimens in **8.4**.

**17.5 Specimen Length**—The length of the specimen shall be such that the compressive force continues to be uniformly distributed throughout the specimen during loading—hence no flexure occurs. To meet this requirement, the specimen shall be a short specimen having a maximum length,  $\ell$ , less than 17 times the least radius of gyration,  $r$ , of the cross section of the specimen (see compressive notations). The minimum length of the specimen for stress and strain measurements shall be greater than three times the larger cross section dimension or about ten times the radius of gyration.

## 18. Procedure

**18.1 Conditioning**—Unless otherwise indicated in the research program or material specification, condition the specimen to constant weight so it is at moisture equilibrium, under the desired environment. Approximate moisture contents with moisture meters or measure more accurately by weights of samples in accordance with Test Methods **D4442**.

### 18.2 Test Setup:

**18.2.1 Bearing Surfaces**—After the specimen length has been calculated in accordance with **18.5**, cut the specimen to the proper length so that the contact surfaces are plane, parallel to each other, and normal to the long axis of the specimen. Furthermore, the axis of the specimen shall be generally parallel to the fibers of the wood.

**NOTE 5**—A sharp fine-toothed saw of either the crosscut or “novelty” crosscut type has been used satisfactorily for obtaining the proper end surfaces. Power equipment with accurate table guides is especially recommended for this work.

**NOTE 6**—It is desirable to have failures occur in the body of the specimen and not adjacent to the contact surface. Therefore, the cross-sectional areas adjacent to the loaded surface may be reinforced.

**18.2.2 Centering**—First geometrically center the specimens on the bearing plates and then adjust the spherical seats so that the specimen is loaded uniformly and axially.

**18.3 Speed of Testing**—The loading shall progress at a constant deformation rate such that the average time to maximum load for the test series shall be at least 4 min. It is permissible to initially test a few random specimens from a series at an alternate rate as the test rate is refined. Otherwise, the selected rate shall be held constant for the test series.

**18.4 Load-Deformation Curves**—If load-deformation data have been obtained, note the load and deflection at first failure, at changes in slope of curve, and at maximum load.

**18.5 Records**—Record the maximum load, as well as a description and sketch of the failure relating the latter to the

location of imperfections in the specimen. Reexamine the section of the specimen containing the failure during analysis of the data.

**18.6 Moisture Content Determination**—Determine the specimen moisture content in accordance with **9.6**.

## 19. Calculation

**19.1** Compute physical and mechanical properties in accordance with Terminology **E6**, and as follows (see compressive notations):

**19.1.1** Stress at proportional limit,  $\sigma'_c = P/A$  in psi (MPa).

**19.1.2** Compressive strength,  $\sigma_c = P_{max}/A$  in psi (MPa).

**19.1.3** Modulus of elasticity,  $E_{axial} = P'/A\varepsilon$  in psi (MPa).

## 20. Report

**20.1** Report the following information:

**20.1.1** Complete identification;

**20.1.2** History of seasoning and conditioning;

**20.1.3** Load apparatus;

**20.1.4** Deflection apparatus;

**20.1.5** Length and cross-section dimensions;

**20.1.6** Gauge length;

**20.1.7** Rate of load application;

**20.1.8** Computed physical and mechanical properties, including specific gravity and moisture content, compressive strength, stress at proportional limit, modulus of elasticity, and a statistical measure of variability of these values;

**20.1.9** Description of failure; and

**20.1.10** Details of any deviations from the prescribed or recommended methods as outlined in the standard.

## COMPRESSION PARALLEL TO GRAIN (CRUSHING STRENGTH OF Laterally SUPPORTED LONG SPECIMEN, EFFECTIVE $\ell/r \geq 17$ )

### 21. Scope

**21.1** This test method covers the determination of the compressive properties of structural members when such a member has a slenderness ratio (length to least radius of gyration) of more than 17, and when such a member is to be evaluated in full size but with lateral supports that are spaced to produce an effective slenderness ratio,  $\ell/r$ , of less than 17. This test method is intended primarily for structural members of rectangular cross section but is also applicable to irregularly shaped studs, braces, chords, round poles and piles, or special sections.

### 22. Summary of Test Method

**22.1** The compression specimen is subjected to a force uniformly distributed on the contact surface in a direction generally parallel to the longitudinal axis of the wood fibers, and the force generally is uniformly distributed throughout the specimen during loading to failure without flexure along its length.

### 23. Significance and Use

**23.1** The compressive properties obtained by axial compression will provide information similar to that stipulated for flexural properties in Section **6**.



23.2 The compressive properties parallel to grain include modulus of elasticity ( $E_{axial}$ ), stress at proportional limit, compressive strength, and strain data beyond proportional limit.

## 24. Apparatus

24.1 *Testing Machine*—Any device having the following is suitable:

24.1.1 *Drive Mechanism*—A drive mechanism for imparting to a movable loading head a uniform, controlled velocity with respect to the stationary base.

24.1.2 *Load Indicator*—A load-indicating mechanism capable of showing the total compressive force on the specimen. This force-measuring system shall be calibrated to ensure accuracy in accordance with Practices E4.

24.2 *Bearing Blocks*—Bearing blocks shall be used to apply the load uniformly over the two contact surfaces and to prevent eccentric loading on the specimen. One spherical bearing block shall be used to ensure uniform bearing, or a rocker-type bearing block shall be used on each end of the specimen with their axes of rotation at 0° to each other (Fig. 6). The radius of the sphere shall be as small as practicable, in order to facilitate adjustment of the bearing plate to the specimen, and yet large enough to provide adequate spherical bearing area. This radius is usually one to two times the greatest cross-section dimension. The center of the sphere shall be on the plane of the specimen contact surface. The size of the compression plate shall be larger than the contact surface.

### 24.3 Lateral Support:

24.3.1 *General*—Evaluation of the crushing strength of long compression specimens requires that they be supported laterally to prevent buckling during the test without undue pressure against the sides of the specimen. Furthermore, the support shall not restrain either the longitudinal compressive deformation or load during test. The support shall be either continuous or intermittent. Intermittent supports shall be spaced so that the distance between supports ( $l_1$  or  $l_2$ ) is less than 17 times the least radius of gyration of the cross section.

24.3.2 *Rectangular Specimens*—The general rules for lateral support outlined in 24.3.1 shall also apply to rectangular specimens. However, the effective column length as controlled by intermittent support spacing on flatwise face ( $l_2$ ) need not equal that on edgewise face ( $l_1$ ). The minimum spacing of the supports on the flatwise face shall be 17 times the least radius

of gyration of the cross section, which is about the centroidal axis parallel to flat face. And the minimum spacing of the supports on the edgewise face shall be 17 times the other radius of gyration (Fig. 6). A satisfactory method of providing lateral support for 2-in. nominal (38-mm) dimension stock is shown in Fig. 7. A 27-in. (686-mm) I-beam provides the frame for the test machine. Small I-beams provide reactions for longitudinal pressure. A pivoted top I-beam provides lateral support on one flatwise face, while the web of the large I-beam provides the other. In between these steel members, metal guides on 3-in. (7.6-cm) spacing (hidden from view) attached to plywood fillers provide the flatwise support and contact surface. In between the flanges of the 27-in. (686-mm) I-beam, fingers and wedges provide edgewise lateral support.

### 24.4 Compressometer:

24.4.1 *Gauge Length*—For modulus of elasticity ( $E_{axial}$ ) calculations, a device shall be provided by which the deformation of the specimen is measured with respect to specific paired gauge points defining the gauge length. To obtain data representative of the test material as a whole, such paired gauge points shall be located symmetrically on the lengthwise surface of the specimen as far apart as feasible, yet at least one times the larger cross-sectional dimension from each of the contact surfaces. At least two pairs of such gauge points on the opposite sides of the specimen shall be used to measure the average deformation.

24.4.2 *Accuracy*—The device shall be able to measure changes in deformation to three significant figures. Since gauge lengths vary over a wide range, the measuring instruments should conform to their appropriate class in accordance with Practice E83.

## 25. Compression Specimen

25.1 *Material*—The specimen shall consist of a structural member that is greater than nominal 2 by 2-in. (38 by 38-mm) in cross section (see 3.2.7).

25.2 *Identification*—Material or materials of the specimen shall be as fully described as for flexure specimens in 8.2.

25.3 *Specimen Measurements*—The weight and dimensions (length and cross-section) of the specimen shall be measured before the test to three significant figures. Sufficient measurements of the cross section shall be made along the length of the specimen to describe shape characteristics and to determine the smallest section. The physical characteristics of the specimen, as described by its density or specific gravity shall be permitted to be determined in accordance with Test Methods D2395.

25.4 *Specimen Description*—The inherent imperfections and intentional modifications shall be described as for flexure specimens in 8.4.

25.5 *Specimen Length*—The cross-sectional and length dimensions of structural members usually have established sizes, depending on the manufacturing process and intended use, so that no modification of these dimensions is involved. Since the length has been approximately established, the full length of the member shall be tested, except for trimming or squaring the bearing surface (see 26.2.1).

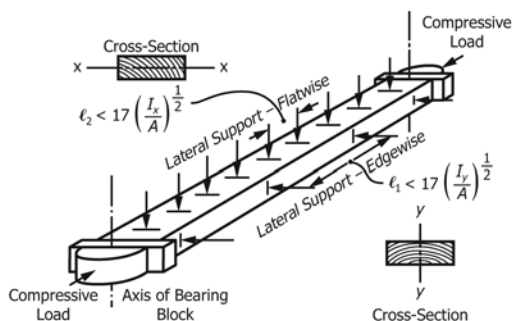
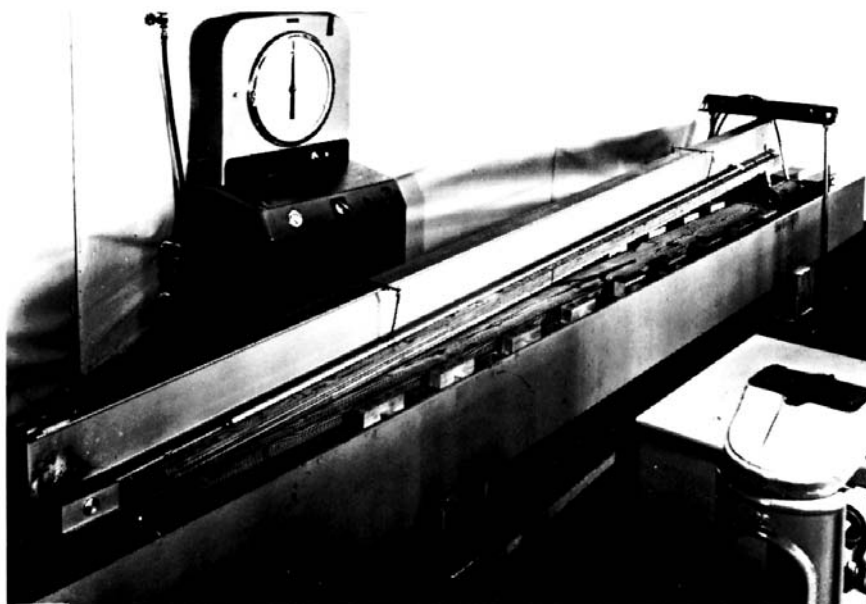

FIG. 6 Minimum Spacing of Lateral Supports of Long Compression Specimens



**FIG. 7 Example Test Setup for a Long Specimen Compression Parallel to Grain Test**

## 26. Procedure

26.1 *Preliminary*—Unless otherwise indicated in the research program or material specification, condition the specimen to constant weight so it is at moisture equilibrium, under the desired environment. Moisture contents may be approximated with moisture meters or more accurately measured by weights of samples in accordance with Test Methods [D4442](#).

### 26.2 Test Setup:

26.2.1 *Bearing Surfaces*—Cut the bearing surfaces of the specimen so that the contact surfaces are plane, parallel to each other, and normal to the long axis of the specimen.

26.2.2 *Setup Method*—After physical measurements have been taken and recorded, place the specimen in the testing machine between the bearing blocks at each end and between the lateral supports on the four sides. Center the contact surfaces geometrically on the bearing plates and then adjust the spherical seats for full contact. Apply a slight longitudinal pressure to hold the specimen while the lateral supports are adjusted and fastened to conform to the warp, twist, or bend of the specimen.

26.3 *Speed of Testing*—The loading shall progress at a constant deformation rate such that the average time to maximum load for the test series shall be at least 4 min. It is permissible to initially test a few random specimens from a series at an alternate rate as the test rate is refined. Otherwise, the selected rate shall be held constant for the test series.

26.4 *Load-Deformation Curves*—If load-deformation data have been obtained, note load and deflection at first failure, at changes in slope of curve, and at maximum load.

26.5 *Records*—Record the maximum load as well as a description and sketch of the failure relating the latter to the location of imperfections in the specimen. Reexamine the section of the specimen containing the failure during analysis of the data.

26.6 *Moisture Content Determination*—Determine the specimen moisture content in accordance with [9.6](#).

## 27. Calculation

27.1 Compute physical and mechanical properties in accordance with Terminology [E6](#) and as follows (see [Appendix X1](#)):

27.1.1 Stress at proportional limit,  $\sigma'_c = P/A$  in psi (MPa).

27.1.2 Compressive strength,  $\sigma_c = P_{max}/A$  in psi (MPa).

27.1.3 Modulus of elasticity,  $E_{axial} = P/A\epsilon$  in psi (MPa).

## 28. Report

28.1 Report the following information:

28.1.1 Complete identification;

28.1.2 History of seasoning conditioning;

28.1.3 Load apparatus;

28.1.4 Deflection apparatus;

28.1.5 Length and cross-section dimensions;

28.1.6 gauge length;

28.1.7 Rate of load application;

28.1.8 Computed physical and mechanical properties, including specific gravity of moisture content, compressive strength, stress at proportional limit, modulus of elasticity, and a statistical measure of variability of these values;

28.1.9 Description of failure; and

28.1.10 Details of any deviations from the prescribed or recommended methods as outlined in the standard.

## TENSION PARALLEL TO GRAIN

## 29. Scope

29.1 This test method covers the determination of the tensile properties of structural members equal to and greater than nominal 1 in. (19 mm) thick.

### 30. Summary of Test Method

30.1 The tension specimen is clamped at the extremities of its length and subjected to a tensile load so that in sections between clamps the tensile forces shall be axial and generally uniformly distributed throughout the cross sections without flexure along its length.

### 31. Significance and Use

31.1 The tensile properties obtained by axial tension will provide information similar to that stipulated for flexural properties in Section 6.

31.2 The tensile properties obtained include modulus of elasticity ( $E_{axial}$ ), stress at proportional limit, tensile strength, and strain data beyond proportional limit.

### 32. Apparatus

32.1 *Testing Machine*—Any device having the following is suitable:

32.1.1 *Drive Mechanism*—A drive mechanism for imparting to a movable clamp a uniform, controlled velocity with respect to a stationary clamp.

32.1.2 *Load Indicator*—A load-indicating mechanism capable of showing the total tensile force on the test section of the tension specimen. This force-measuring system shall be calibrated to ensure accuracy in accordance with Practices E4.

32.1.3 *Grips*—Suitable grips or fastening devices shall be provided that transmit the tensile load from the movable head of the drive mechanism to one end of the test section of the tension specimen, and similar devices shall be provided to transmit the load from the stationary mechanism to the other end of the test section of the specimen. Such devices shall be designed to minimize slippage under load, inflicted damage, or inflicted stress concentrations to the test section. Such devices shall be permitted to be plates bonded to the specimen or un-bonded plates clamped to the specimen by various pressure modes.

32.1.3.1 *Grip Alignment*—The fastening device shall apply the tensile loads to the test section of the specimen without applying a bending moment.

NOTE 7—For ideal test conditions, the grips should be self-aligning, that is, they should be attached to the force mechanism of the machine in such a manner that they will move freely into axial alignment as soon as the load is applied, and thus apply uniformly distributed forces along the test section and across the test cross section (Fig. 8(a)). For less ideal test conditions, each grip should be gimbaled about one axis, which should be perpendicular to the wider surface of the rectangular cross section of the specimen, and the axis of rotation should be through the fastened area (Fig. 8(b)). When neither self-aligning grips nor single gimbaled grips are available, the specimen may be clamped in the test machine with grips providing full restraint (Fig. 8(c)). A method of providing approximately full spherical alignment has three axes of rotation, not necessarily concurrent but, however, having a common axis longitudinal and through the centroid of the specimen (Fig. 8(d) and Fig. 9).

32.1.3.2 *Contact Surface*—The contact surface between grips and specimen shall be such that slippage does not occur.

NOTE 8—A smooth texture on the grip surface should be avoided, as well as very rough and large projections that damage the contact surface of the wood. Grips that are surfaced with a coarse emery paper (60× aluminum oxide emery belt) or serrated metal have been found satisfactory for softwoods. However, for hardwoods, grips may have to be glued

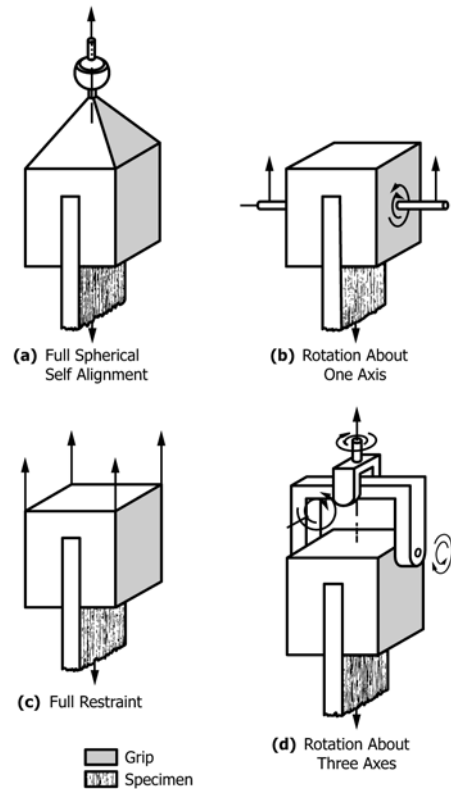

FIG. 8 Types of Tension Grips for Tension Specimens

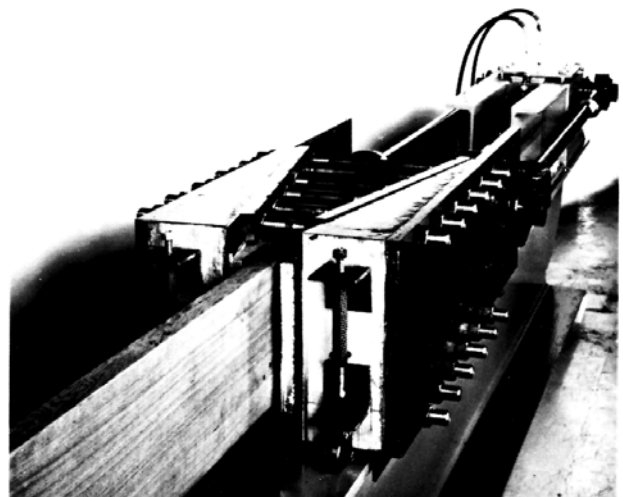

FIG. 9 Horizontal Tensile Grips for Nominal 2 × 10-in. (38 × 235-mm) Tension Specimens

to the specimen to prevent slippage.

32.1.3.3 *Contact Pressure*—For un-bonded grip devices, lateral pressure shall be applied to the jaws of the grip to prevent slippage between the grip and specimen. Such pressure is permitted to be applied using bolts, wedge-shaped jaws, hydraulic grips, pneumatic grips or other suitable means. To eliminate stress concentration or compressive damage at the tip end of the jaw closest to the tested segment, the contact pressure shall be reduced to zero.



NOTE 9—Wedge-shaped jaws, such as those shown in Fig. 10, which slip on the inclined plane to produce contact pressure, have a variable contact surface, and apply a lateral pressure gradient, have been found satisfactory.

32.1.4 Extensometer:

32.1.4.1 Gauge Length—For modulus of elasticity determinations, a device shall be provided by which the elongation of the test section of the specimen is measured with respect to specific paired gauge points defining the gauge length. To obtain data representative of the test material as a whole, such gauge points shall be symmetrically located on the lengthwise surface of the specimen as far apart as feasible, yet at least two times the larger cross-sectional dimension from each jaw edge. At least two pairs of such gauge points on the opposite sides of the specimen shall be used to measure the average deformation.

32.1.4.2 Accuracy—The device shall be able to measure changes in elongation to three significant figures. Since gauge lengths vary over a wide range, the measuring instruments should conform to their appropriate class in accordance with Practice E83.

33. Tension Specimen

33.1 Material—The specimen shall consist of a structural member with a size used in structural “tensile” applications, that is, in sizes equal to and greater than nominal 1-in. (19-mm) thick lumber

33.2 Identification—Material or materials of the specimen shall be fully described as required for flexure specimens in 8.2.

33.3 Specimen Description—The specimen shall be described in a manner similar to that outlined in 8.3 and 8.4.

33.4 Specimen Length—The tension specimen, which has its long axis parallel to grain in the wood, shall have a length between grips equal to at least eight times the larger cross-sectional dimension.

NOTE 10—A length of eight times the larger cross-sectional dimension is considered sufficient to uniformly distribute stress across the cross-section and minimize the influence of eccentric load application with self-aligning grips. When testing without self-aligning grips, a longer gauge length may be required to minimize the influence from the application of an eccentric tension load. Between-grip distances that are 20 or more times the greater cross-sectional dimension may be appropriate.

34. Procedure

34.1 Conditioning—Unless otherwise indicated, condition the specimen as outlined in 9.1.

34.2 Test Setup—After physical measurements have been taken and recorded, place the specimen in the grips of the load mechanism, taking care to have the long axis of the specimen and the grips coincide. The grips should securely clamp the specimen. If wedge-shaped jaws are employed, apply a small preload to ensure that all jaws move an equal amount and maintain axial-alignment of specimen and grips. Regardless of grip type, tighten the grips evenly and firmly to the degree necessary to prevent slippage. Under load, continue the tightening as necessary to eliminate slippage and achieve a tensile failure outside the jaw contact area.

NOTE 11—Some amount of perpendicular-to-grain crushing of the wood in the grips may be tolerable provided that the tension failures consistently occur outside of the grips. If failures consistently occur within the grips, then the grip pressure should be reduced as required to force failures to occur within the tested gauge length.

34.3 Speed of Testing—The loading shall progress at a constant deformation rate such that the average time to maximum load for the test series shall be at least 4 min. It is permissible to initially test a few random specimens from a series at an alternate rate as the test rate is refined. Otherwise, the selected rate shall be held constant for the test series.

34.4 Load-Elongation Curves—If load-elongation data have been obtained throughout the test, correlate changes in specimen behavior, such as appearance of cracks or splinters, with elongation data.

34.5 Records—Record the maximum load, as well as a description and sketch of the failure relating the latter to the location of imperfections in the test section. Reexamine the section containing the failure during analysis of data.

34.6 Moisture Content Determination—Determine the specimen moisture content in accordance with 9.6.

35. Calculation

35.1 Compute physical and mechanical properties in accordance with Terminology E6, and as follows (see Appendix X1):

- 35.1.1 Stress at proportional limit,  $\sigma'_t = P/A$  in psi (MPa).
- 35.1.2 Tensile strength,  $\sigma_t = P_{max}/A$  in psi (MPa).
- 35.1.3 Modulus of elasticity,  $E_{axial} = P/A\varepsilon$  in psi (MPa).

36. Report

- 36.1 Report the following information:
  - 36.1.1 Complete identification,

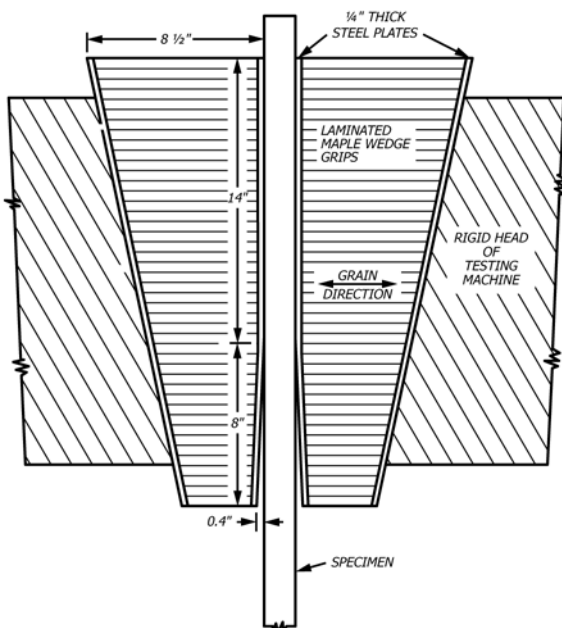

FIG. 10 Side View of Wedge Grips Used to Anchor Full-Size, Structurally-Graded Tension Specimens



- 36.1.2 History of seasoning,
- 36.1.3 Load apparatus, including type of end condition,
- 36.1.4 Deflection apparatus,
- 36.1.5 Length and cross-sectional dimensions,
- 36.1.6 Gauge length,
- 36.1.7 Rate of load application,
- 36.1.8 Computed physical and mechanical properties, including specific gravity and moisture content, tensile strength, stress at proportional limit, modulus of elasticity, and a statistical measure of variability of these values,
- 36.1.9 Description of failures, and
- 36.1.10 Details of any deviations from the prescribed or recommended methods as outlined in the standard.

## TORSION

### 37. Scope

37.1 This test method covers the determination of the torsional properties of structural members. This test method is intended primarily for specimens of rectangular cross section, but is also applicable to round or irregular shapes.

### 38. Summary of Test Method

38.1 The specimen is subjected to a torsional moment by clamping it near its ends and applying opposing couples to each clamping device. The specimen is deformed at a prescribed rate and coordinate observations of torque and twist are made for the duration of the test.

### 39. Significance and Use

39.1 The torsional properties obtained by twisting the specimen will provide information similar to that stipulated for flexural properties in Section 6.

39.2 The torsional properties of the specimen include torsional shear modulus ( $G_T$ ), stress at proportional limit, torsional strength, and twist beyond proportional limit.

### 40. Apparatus

40.1 *Testing Machine*—Any device having the following is suitable:

40.1.1 *Drive Mechanism*—A drive mechanism for imparting an angular displacement at a uniform rate between a movable clamp on one end of the specimen and another clamp at the other end.

40.1.2 *Torque Indicator*—A torque-indicating mechanism capable of showing the total couple on the specimen. This measuring system shall be calibrated to ensure accuracy in accordance with Practices E4.

#### 40.2 *Support Apparatus:*

40.2.1 *Clamps*—Each end of the specimen shall be securely held by metal plates of sufficient bearing area and strength to grip the specimen with a vise-like action without slippage, damage, or stress concentrations in the test section when the torque is applied to the assembly. The plates of the clamps shall be symmetrical about the longitudinal axis of the cross section of the element.

40.2.2 *Clamp Supports*—Each of the clamps shall be supported by roller bearings or bearing blocks that allow the

specimen to rotate about its natural longitudinal axis. Such supports shall be permitted to be ball bearings in a rigid frame of a torque-testing machine (Figs. 11 and 12) or bearing blocks (Figs. 13 and 14) on the stationary and movable frames of a universal-type test machine. Either type of support shall allow the transmission of the couple without friction to the torque measuring device, and shall allow freedom for longitudinal movement of the specimen during the twisting. Apparatus of Fig. 13 is not suitable for large amounts of twist unless the angles are measured at each end to enable proper torque calculation.

40.2.3 *Frame*—The frame of the torque-testing machine shall be capable of providing the reaction for the drive mechanism, the torque indicator, and the bearings. The framework necessary to provide these reactions in a universal-type test machine shall be two rigid steel beams attached to the movable and stationary heads forming an X. The extremities of the X shall bear on the lever arms attached to the specimen (Fig. 13).

#### 40.3 *Troptometer:*

40.3.1 *Gauge Length*—For torsional shear modulus calculations, a device shall be provided by which the angle of twist of the specimen is measured with respect to specific paired gauge points defining the gauge length. To obtain test data representative of the element as a whole, such paired gauge points shall be located symmetrically on the lengthwise surface of the specimen as far apart as feasible, yet at least two times the larger cross-sectional dimension from each of the clamps. A yoke (Fig. 15) or other suitable device (Fig. 12) shall be firmly attached at each gauge point to permit measurement of the angle of twist. The angle of twist is measured by observing the relative rotation of the two yokes or other devices at the gauge points with the aid of any suitable apparatus including a light beam (Fig. 12), dials (Fig. 14), or string and scale (Figs. 15 and 16).

40.3.2 *Accuracy*—The device shall be able to measure changes in twist to three significant figures. Since gauge lengths may vary over a wide range, the measuring instruments should conform to their appropriate class in accordance with Practice E83.

### 41. Torsion Specimen

41.1 *Material*—The specimen shall consist of a structural member in sizes that are used in structural applications.

41.2 *Identification*—Material or materials of the specimen shall be as fully described as for flexure specimens in 8.2.

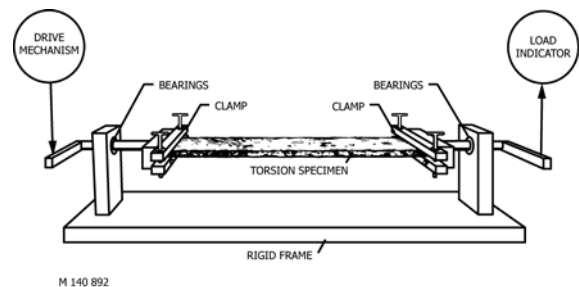

**FIG. 11 Fundamentals of a Torsional Test Machine**

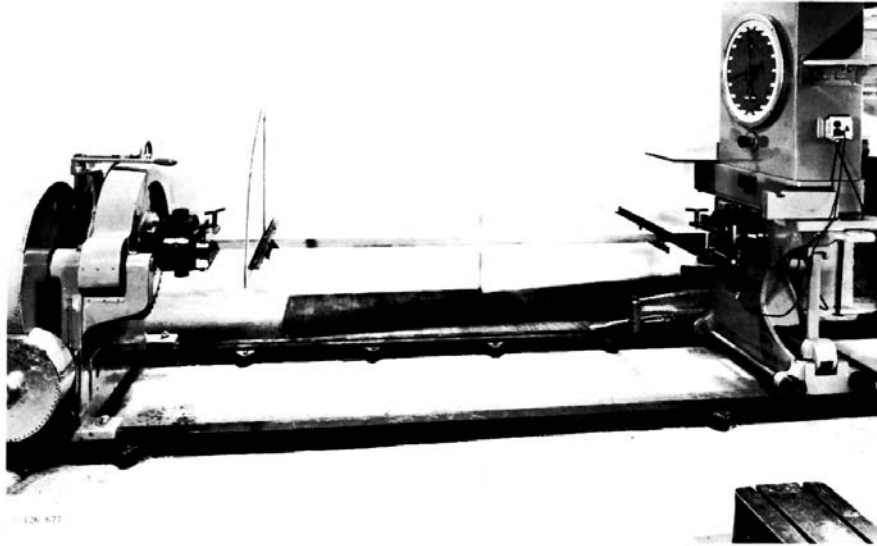

FIG. 12 Example of Torque-Testing Machine (Torsion specimen in apparatus meeting specification requirements)

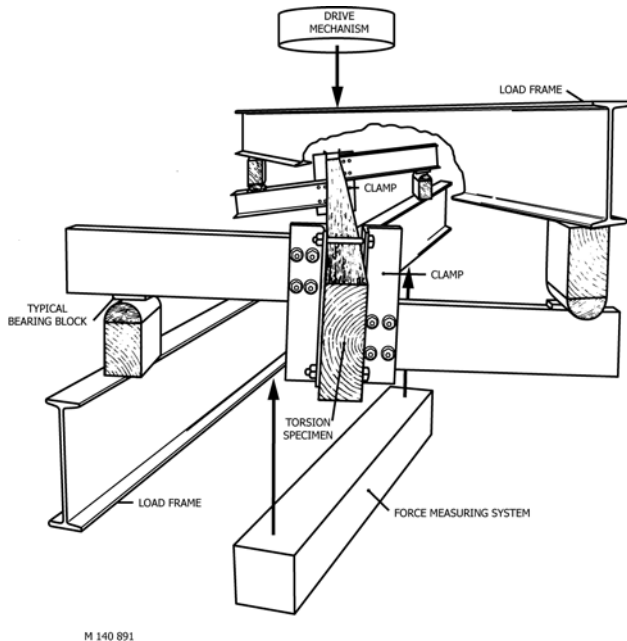

FIG. 13 Schematic Diagram of a Torsion Test Made in a Universal-Type Test Machine

41.3 *Specimen Measurements*—The weight and dimensions (length and cross-section) shall be measured to three significant figures. Sufficient measurements of the cross section shall be made along the length of the specimen to describe characteristics and to determine the smallest section. The physical characteristics of the specimen, as described by its density or specific gravity, shall be permitted to be determined in accordance with Test Methods [D2395](#).

41.4 *Specimen Description*—The inherent imperfections and intentional modifications shall be described as for flexure specimens in [8.4](#).

41.5 *Specimen Length*—The cross-sectional dimensions are usually established, depending upon the manufacturing process and intended use so that normally no modification of these dimensions is involved. However, the length of the specimen shall be at least eight times the larger cross-sectional dimension.

## 42. Procedure

42.1 *Conditioning*—Unless otherwise indicated in the research program or material specification, condition the specimen to constant weight so it is at moisture equilibrium under the desired environment. Approximate moisture contents with moisture meters, or measure more accurately by weights of samples in accordance with Test Methods [D4442](#).

42.2 *Test Setups*—After physical measurements have been taken and recorded, place the specimen in the clamps of the load mechanism, taking care to have the axis of rotation of the clamps coincide with the longitudinal centroidal axis. Tighten the clamps to securely hold the specimen in either type of testing machine. If the tests are made in a universal-type test machine, the bearing blocks shall be equal distances from the axis of rotation.

42.3 *Speed of Testing*—The loading shall progress at a constant deformation rate such that the average time to maximum load for the test series shall be at least 4 min. It is permissible to initially test a few random specimens from a series at an alternate rate as the test rate is refined. Otherwise, the selected rate shall be held constant for the test series.

42.4 *Torque-Twist Curves*—If torque-twist data have been obtained, note torque and twist at first failure, at changes in slope of curve, and at maximum torque.

42.5 *Record of Failures*—Describe failures in detail as to type, manner, and order of occurrence, angle with the grain, and position in the specimen. Record descriptions relating to imperfections in the specimen. Reexamine the section of the specimen containing the failure during analysis of the data.

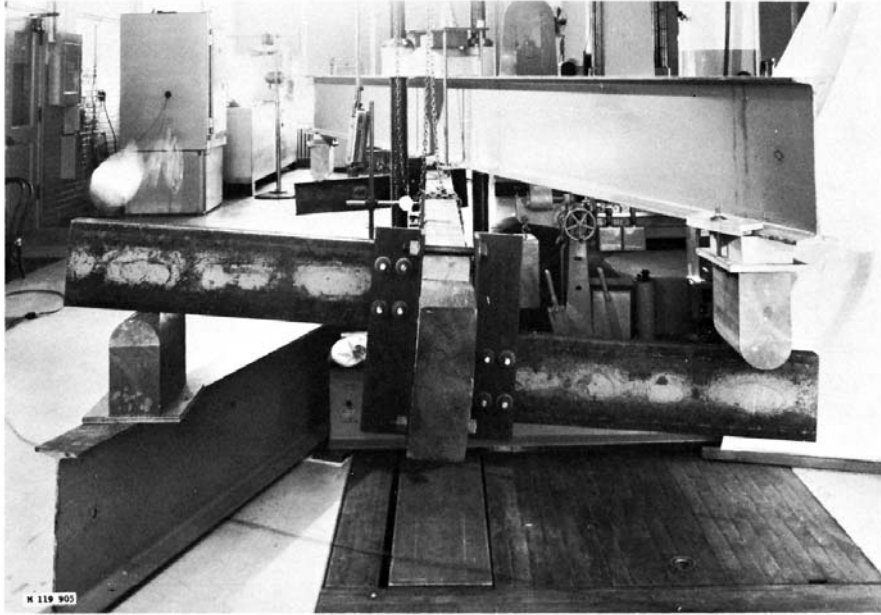

FIG. 14 Example of Torsion Test of Structural Member in a Universal-Type Test Machine

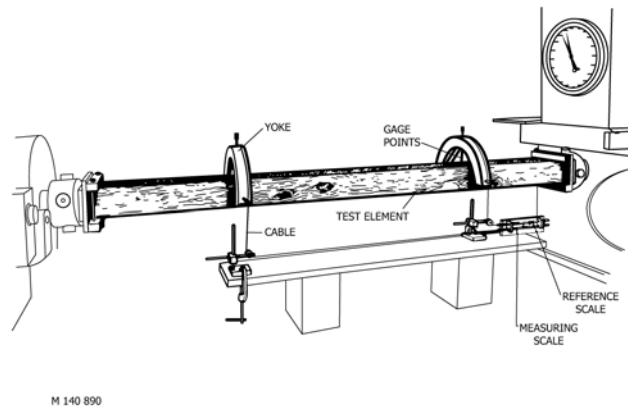

FIG. 15 Troptometer Measuring System

42.6 *Moisture Content Determination*—Determine the specimen moisture content in accordance with 9.6.

### 43. Calculation

43.1 Compute physical and mechanical properties in accordance with Terminology E6 and relationships in Tables X3.1 and X3.2.

### 44. Report

- 44.1 Report the following information:
  - 44.1.1 Complete identification,
  - 44.1.2 History of seasoning and conditioning,
  - 44.1.3 Apparatus for applying and measuring torque,
  - 44.1.4 Apparatus for measuring angle of twist,
  - 44.1.5 Length and cross-section dimensions,
  - 44.1.6 Gauge length,

- 44.1.7 Rate of twist applications,
- 44.1.8 Computed physical and mechanical properties, including specific gravity and moisture content, torsional strength, stress at proportional limit, torsional shear modulus, and a statistical measure of variability of these values, and
- 44.1.9 Description of failures.

## SHEAR MODULUS

### 45. Scope

45.1 This test method covers the determination of the shear modulus ( $G$ ) of structural members. Application to composite constructions can only give a measure of the effective shear modulus. This test method is intended primarily for specimens of rectangular cross section but is also applicable to other sections with appropriate modification of equation coefficients.



FIG. 16 Torsion Test with Yoke-Type Troptometer

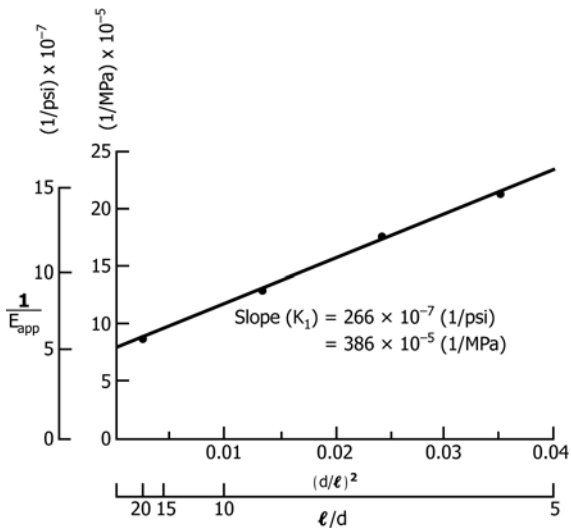

FIG. 17 Determination of Shear Modulus

#### 46. Summary of Test Method

46.1 The shear modulus specimen, usually a straight or a slightly cambered member of rectangular cross section, is subjected to a bending moment by supporting it at two locations called reactions, and applying a single transverse load midway between these reactions. The specimen is deflected at a prescribed rate and a single observation of coordinate load and deflection is taken. This procedure is repeated on at least four different spans.

#### 47. Significance and Use

47.1 The shear modulus established by this test method will provide information similar to that stipulated for flexural properties in Section 6.

#### 48. Apparatus

48.1 The test machine and specimen configuration, supports, and loading are identical to Section 7 with the following exception:

48.1.1 The load shall be applied as a single, concentrated load midway between the reactions.

#### 49. Shear Modulus Specimen

49.1 See Section 8.

#### 50. Procedure

50.1 *Conditioning*—See 9.1.

50.2 *Test Setup*—Position the specimen in the test machine as described in 9.2 and load in center point bending over at least four different spans with the same cross section at the center of each. Choose the spans so as to give approximately equal increments of  $(d/l)^2$  between them, within the range from 0.035 to 0.0025. The applied load must be sufficient to provide a reliable estimate of the initial bending stiffness of the specimen, but in no instance shall exceed the proportional limit or shear capacity of the specimen.

NOTE 12—Span-to-depth ratios of 5.5, 6.5, 8.5, and 20.0 meet the  $(d/l)^2$  requirements of this section.

50.3 *Load-Deflection Measurements*—Obtain load-deflection data with the apparatus described in 7.4.1. One data point is required on each span tested.

50.4 *Records*—Record span-to-depth ( $l/d$ ) ratios chosen and load levels achieved on each span.

50.5 *Speed of Testing*—See 9.3.

#### 51. Calculation

51.1 Determine shear modulus,  $G$ , by plotting  $1/E_{app}$  (where  $E_{app}$  is the apparent modulus of elasticity calculated under center point loading) versus  $(d/l)^2$  for each span tested. As indicated in Fig. 17 and in Appendix X4, shear modulus is proportional to the slope of the best-fit line between these points.

#### 52. Report

52.1 See Section 11.



## PRECISION AND BIAS

## 54. Keywords

### 53. Precision and Bias

53.1 The precision and bias of the flexure test method are discussed in Section 12. For the other test methods, the precision and bias have not been established.

54.1 apparent modulus of elasticity; compression; flexure; modulus of elasticity; modulus of rupture; shear; shear modulus; shear-free modulus of elasticity; structural members; tension; torsion; torsional shear modulus; wood; wood-based materials

## APPENDIXES

### (Nonmandatory Information)

## X1. NOTATIONS

### INTRODUCTION

Notations are divided into sections corresponding to the test methods. Notations common to two or more test methods (for example, compression and tension or flexure and shear modulus) are listed in X1.1.

### X1.1 GENERAL

$A$	Cross-sectional area, in. <sup>2</sup> (mm <sup>2</sup> ).	$P$	Increment of applied load on flexure or shear modulus specimen below proportional limit, lbf (N).
$d$	Depth of rectangular flexure, shear modulus, or torsion specimen, in. (mm).	$P'$	Applied load at proportional limit, lbf (N).
$D$	Diameter of circular specimen, in. (mm).	$P_{max}$	Maximum load borne by specimen loaded to failure, lbf (N).
$E_{app}$	Apparent modulus of elasticity, psi (MPa).	$r$	Radius of gyration = $\sqrt{I/A}$ , in. (mm).
$E_{axial}$	Axial modulus of elasticity, psi (MPa).	$z$	Rate of outer fiber strain, in./in./min (mm/mm/min).
$E_{sf}$	Shear-free modulus of elasticity, psi (MPa).	$\Delta$	Increment of deflection of neutral axis of flexure or shear modulus specimen measured at midspan over distance $\ell$ and corresponding load $P$ , in. (mm).
$G$	Shear modulus, psi (MPa).	$\epsilon$	Strain at proportional limit, in./in. (mm/mm)
$I$	Moment of inertia of the cross section about a designated axis, in. <sup>4</sup> (mm <sup>4</sup> ).	$\sigma_c$	Compression strength, psi (MPa).
$\ell$	Span of flexure or shear modulus specimen or length of compression specimen, in. (mm).	$\sigma'_c$	Compression stress at the proportional limit, psi (MPa).
$\ell_1$ or $\ell_2$	Effective length of compression specimen between supports for lateral stability, in. (mm).	$\sigma_t$	Tension strength, psi (MPa).
$N$	Rate of motion of movable head, in./min (mm/min).	$\sigma'_t$	Tension stress at the proportional limit, psi (MPa).

### X1.2 FLEXURE

$a$	Distance from reaction to nearest load point, in. (mm) ( $\frac{1}{2}$ shear span).	$M$	Maximum bending moment borne by a flexure specimen, lbf-in. (N-m).
$A_{ML}$	Area of graph paper under load-deflection curve from zero load to maximum load when deflection is measured at midspan over distance $\ell$ , in. <sup>2</sup> (mm <sup>2</sup> ).	$S'$	Fiber stress at proportional limit, psi (MPa).

$A_{TL}$	Area of graph paper under load-deflection curve from zero load to failing load or arbitrary terminal load when deflection is measured at midspan over distance $\ell$ , in. <sup>2</sup> (mm <sup>2</sup> ).	$S_R$	Modulus of rupture, psi (MPa).
$b$	Width of flexure specimen, in. (mm).	$W_{PL}$	Work to proportional limit per unit volume, in.-lbf/in. <sup>3</sup> (kJ/m <sup>3</sup> ).
$c$	Distance from neutral axis of flexure specimen to extreme outer fiber, in. (mm).	$W_{ML}$	Approximate work to maximum load per unit volume, in.-lbf/in. <sup>3</sup> (kJ/m <sup>3</sup> ).
$c_1$	Graph paper scale constant for converting unit area of graph paper to load-deflection units, lb/in. (N/mm).	$W_{TL}$	Approximate total work per unit volume, in.-lbf/in. <sup>3</sup> (kJ/m <sup>3</sup> ).
$c_2$	Ratio between deflection at the load point and deflection at the midspan.	$\Delta_{sf}$	Increment of deflection of flexure specimen's neutral axis measured at midspan over distance $\ell_{sf}$ and corresponding load $P$ , in. (mm).
$\ell_{sf}$	Length of flexure specimen that is used to measure deflection between two load points, that is, shear-free deflection, in. (mm).	$\tau_{max}$	Maximum shear stress, psi (MPa).

### X1.3 TORSION

$G_t$	Torsional shear modulus, psi (MPa).	$T$	Twisting moment or torque, lbf-in. (N-m).
$K$	Stiffness-shape factor. <sup>A</sup>	$T'$	Torque at proportional limit, lbf-in. (N-m).
$\ell_g$	gauge length of torsion specimen, in. (mm).	$b$	Width of rectangular specimen, in. (mm).
$Q$	Stress-shape factor. <sup>A</sup>	$\gamma$	St. Venant constant, Column C, Table X3.2.
$S_s$	Fiber shear stress of greatest intensity at middle of long side at maximum torque, psi (MPa).	$\gamma_1$	St. Venant constant, Column D, Table X3.2.
$S_s'$	Fiber shear stress of greatest intensity at middle of long side at proportional limit, psi (MPa).	$\theta$	Total angle of twist, radians (in./in. or mm/mm).
$S_s''$	Fiber shear stress of greatest intensity at middle of short side at maximum torque, psi (MPa).	$\lambda$	St. Venant constant, Column A, Table X3.2.
		$\mu$	St. Venant constant, Column B, Table X3.2.

<sup>A</sup> Based upon page 348 of *Roark's Formulas for Stress and Strain (1)* (see Footnote 4).

### X1.4 SHEAR MODULUS

$K$	Shear coefficient. Defined in <a href="#">Appendix X4</a> .	$K_1$	Slope of line through multiple test data plotted on $(d/\ell)^2$ versus $(1/E_{app})$ axes (see <a href="#">Fig. 17</a> ).
-----	---	-------	--

**X2. FLEXURE**

X2.1 Flexure formulas for specimens with solid rectangular homogeneous cross-section through their length are shown in **Table X2.1**. These formulas are generally applicable for lumber and wood-based materials. Structural members composed of dissimilar materials (for example, sandwich-type structures) or those assembled with semi-rigid connections (for example, built-up beams with mechanical fasteners) should be analyzed using more rigorous methods.

X2.2 Schematic diagrams of loading methods are shown in **Fig. X2.1**. In this standard, two-point loading is the case when

the load is applied equally at two points equidistant from their reactions (**Fig. X2.1(a)**). Two-point loading is also known as four-point loading, because there are two loads and two reactions acting on the flexure specimen. Third-point loading is a special case of two-point (four-point) loading where the two loads are equally spaced between supports, at one-third span length from reactions (**Fig. X2.1(b)**). Center-point loading, or center loading, is the case when the load is applied at the mid-span (**Fig. X2.1(c)**). It is a special case of three-point loading—one load and two reactions.

**TABLE X2.1 Flexure Formulas**

Line	Mechanical Property	Two-Point Loading (Column A)	Third-Point Loading (Column B)	Center-Point Loading (Column C)
1	Fiber stress at proportional limit, $S'$	$\frac{3Pa}{bd^2}$	$\frac{P'\ell}{bd^2}$	$\frac{3P'\ell}{2bd^2}$
2	Modulus of rupture, $S_R$	$\frac{3P_{max}a}{bd^2}$	$\frac{P_{max}\ell}{bd^2}$	$\frac{3P_{max}\ell}{2bd^2}$
3	Apparent modulus of elasticity, $E_{app}$	$\frac{Pa}{4bd^3\Delta}(3\ell^2 - 4a^2)$	$\frac{23P\ell^3}{108bd^3\Delta}$	$\frac{P\ell^3}{4bd^3\Delta}$
4	Shear-free modulus of elasticity, $E_{sf}$ (determined using $\Delta$ )	$\frac{Pa(3\ell^2 - 4a^2)}{4bd^3\Delta\left(1 - \frac{3Pa}{5bdG\Delta}\right)}$	$\frac{23P\ell^3}{108bd^3\Delta\left(1 - \frac{P\ell}{5bdG\Delta}\right)}$	$\frac{P\ell^3}{4bd^3\Delta\left(1 - \frac{3P\ell}{10bdG\Delta}\right)}$
5	Shear-free modulus of elasticity, $E_{sf}$ (determined using $\Delta_{sf}$ )	$\frac{3Pa\ell_{sf}^2}{4bd^3\Delta_{sf}}$	$\frac{P\ell\ell_{sf}^2}{4bd^3\Delta_{sf}}$	—
6	Ratio between deflection at the load point and deflection at the midspan, $c_2$	$\frac{4a(3\ell - 4a) + \frac{12d^2E_{sf}}{5G}}{3\ell^2 - 4a^2 + \frac{12d^2E_{sf}}{5G}}$	$\frac{20}{9}\ell^2 + \frac{12d^2E_{sf}}{5G}$ $\frac{23}{9}\ell^2 + \frac{12d^2E_{sf}}{5G}$	—
7	Work to proportional limit per unit volume, $W_{PL}$	$\frac{P\Delta c_2}{2\ell bd}$	$\frac{P\Delta c_2}{2\ell bd}$	$\frac{P\Delta}{2\ell bd}$
8	Approximate work to maximum load per unit volume, $W_{ML}$	$\frac{A_{ML}c_1c_2}{\ell bd}$	$\frac{A_{ML}c_1c_2}{\ell bd}$	$\frac{A_{ML}c_1}{\ell bd}$
9	Approximate total work per unit volume, $W_{TL}$	$\frac{A_{TL}c_1c_2}{\ell bd}$	$\frac{A_{TL}c_1c_2}{\ell bd}$	$\frac{A_{TL}c_1}{\ell bd}$
10	Maximum shear stress, $\tau_{max}$	$\frac{3P_{max}}{4bd}$	$\frac{3P_{max}}{4bd}$	$\frac{3P_{max}}{4bd}$

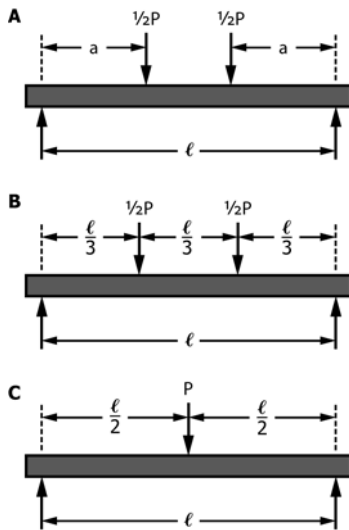

FIG. X2.1 Methods of Loading a Flexure Specimen: (A) Two-Point Loading, (B) Third-Point Loading, and (C) Center-Point Loading

$$S_R = \frac{Mc}{I} \tag{X2.1}$$

Generally, modulus of rupture is determined using the bending moment that causes rupture. In this standard, modulus of rupture is calculated using maximum bending moment at the maximum load,  $P_{max}$ , borne by the specimen, although rupture does not always occur at the maximum load and not necessarily in the zone of maximum moment (especially under center-point loading of lumber).

X2.5 Modulus of elasticity in bending,  $E_{app}$  or  $E_{sf}$  is determined using linear portion of load-deflection (or stress-strain) curve. The maximum slope should be fitted to the load-deformation data by an acceptable statistical or graphical method. Historically, it has been determined graphically, using the slope of a straight line drawn through the linear portion of the load-deflection curve. If digital data acquisition is used, the straight line should be fitted between two different stress levels below proportional limit using appropriate statistical procedures. It is the user's responsibility to choose the stress levels and calculation methods that suit the purpose of testing and material tested. Normally, the curve fitting should cover a minimum range of 20 % of  $S_R$  (for example, between 10 % and 30 % or between 20 % and 40 % of  $S_R$ ). The stress levels and goodness of fit should be included in the report. If digital methods produce questionable results, graphical method should be used as reference.

X2.6 Apparent modulus of elasticity,  $E_{app}$ , includes effect of shear distortion of the flexure specimen cross-section. The shear effect is greater in specimens with low span-depth ratio and materials with low shear modulus. To determine shear-free modulus of elasticity,  $E_{sf}$ , deflections are measured in shear-free span between load points,  $\ell_{sf}$ , using two-point bending method. Alternatively, the shear-free modulus of elasticity can be calculated using full-span deflections,  $\Delta$ , and assuming that the shear modulus,  $G$ , is known (Table X2.1, Line 4); however, this calculation may not necessarily produce the same results as a test.

X2.7 Formulas for flexure specimen's work under two-point and third-point loading include factor  $c_2$ , which relates deflection under the load points to the deflection measured at mid-span. This factor includes shear correction assuming that the ratio  $E_{sf}/G$  is known.

X2.3 Fiber stress at proportional limit,  $S'$ , is determined at the last point on the linear portion of stress-strain (or load-deflection) curve. Historically, it has been determined graphically by drawing a straight line through the linear portion, where the modulus of elasticity is determined, and finding the point where the curve deviated from the straight line. If a digital data acquisition is used, the proportional limit (the point of deviation from the straight line) can be determined using a threshold value of the slope deviation or other suitable criteria. The threshold value depends on the product tested; therefore, it should be correlated with the graphical method using a representative subset of the sample. Threshold values and calculation methods should be included in the report.

X2.4 Modulus of rupture,  $S_R$ , is a measure of maximum load carrying capacity of a flexure specimen. In most wood products, the maximum load and rupture occur beyond the proportional limit where significant plastic deformations develop and the true cross-section stress distribution is unknown. For simplicity, modulus of rupture is calculated assuming the extreme fiber of a specimen is a linear elastic and homogeneous material:



### X3. TORSION

X3.1 Torsion formulas in **Table X3.1** are valid assuming that the tested material is isotropic and linear elastic (obeys the Hooke's law). The values of St. Venant coefficients in **Table X3.2** are from *NACA Report No. 334 (2)*<sup>4</sup> Table I "Factors for

Calculating Torsional Rigidity and Stress of Rectangular Prisms," which is based on an earlier St. Venant's publication. If equation format is preferred by the user, *Roark's Formulas for Stress and Strain (1)* provides approximate expressions for the St. Venant coefficients with sufficient accuracy.

<sup>4</sup> The boldface numbers in parentheses refer to a list of references at the end of this standard.

**TABLE X3.1 Torsion Formulas**

Line	Mechanical Property	Cross Section			
		Circle (Column A)	Square (Column B)	Rectangle (Column C)	General (Column D)
1	Fiber shear stress of greatest intensity at middle of long side; at proportional limit, $S_s'$	$\frac{16T'}{\pi D^3}$	$\frac{4.808 T'}{d^3}$	$\frac{8\gamma T'}{\mu db^2}$	$\frac{T'}{Q}$
2	Fiber shear stress of greatest intensity at middle of long side at maximum torque, $S_s$	$\frac{16T'}{\pi D^3}$	$\frac{4.808 T}{d^3}$	$\frac{8\gamma T}{\mu db^2}$	$\frac{T}{Q}$
3	Fiber shear stress of greatest intensity at middle of short side at maximum torque, $S_s''$			$\frac{8\gamma_1 T}{\mu b^3}$	
4	Torsional shear modulus, $G_t$	$\frac{32\ell_g T'}{\pi D^4\theta}$	$\frac{7.11\ell_g T'}{d^4\theta}$	$\frac{16\ell_g T'}{db^3 \left[ \frac{16}{3} - \frac{\lambda b}{d} \right] \theta}$	$\frac{\ell_g T'}{K\theta}$

X3.2 For most wood and composite materials, the torsional shear modulus,  $G_t$ , obtained using the torsional test method is typically not equivalent to the shear modulus,  $G$ , used elsewhere in this standard. The  $G$  of interest in a flexural application is that which occurs in the plane of flexure. The  $G_t$  values derived using the calculations of **Table X3.1** represent a composite shear estimate that combines the performance of all

planes which occur parallel to the torsional length based upon an assumption that the materials are isotropic. For materials that are not isotropic, the  $G_t$  estimate will be influenced by the shear modulus for each plane that occurs parallel to the torsional length and the cross-sectional geometry relative to those planes.

**TABLE X3.2 Factors for Calculating Torsional Rigidity and Stress of Rectangular Prisms**

Ratio of Sides	$\lambda$ (Column A)	$\mu$ (Column B)	$\gamma$ (Column C)	$\gamma_1$ (Column D)
1.00	3.08410	2.24923	1.35063	1.35063
1.05	3.12256	2.35908	1.39651	
1.10	3.15653	2.46374	1.43956	
1.15	3.18554	2.56330	1.47990	
1.20	3.21040	2.65788	1.51753	
1.25	3.23196	2.74772	1.55268	1.13782
1.30	3.25035	2.83306	1.58544	
1.35	3.26632	2.91379	1.61594	
1.40	3.28002	2.99046	1.64430	
1.45	3.29171	3.06319	1.67265	
1.50	3.30174	3.13217	1.69512	0.97075
1.60	3.31770	3.25977	1.73889	0.91489
1.70	3.32941	3.37486	1.77649	
1.75	3.33402	3.42843	1.79325	0.84098
1.80	3.33798	3.47890	1.80877	
1.90	3.34426	3.57320	1.83643	
2.00	3.34885	3.65891	1.86012	0.73945
2.25	3.35564	3.84194	1.90543	
2.50	3.35873	3.98984	1.93614	0.59347
2.75	3.36023	4.11143	1.95687	
3.00	3.36079	4.21307	1.97087	
3.33	...	...	...	0.44545
3.50	3.36121	4.37299	1.98672	
4.00	3.36132	4.49300	1.99395	0.37121
4.50	3.36133	4.58639	1.99724	
5.00	3.36133	4.66162	1.99874	0.29700
6.00	3.36133	4.77311	1.99974	
6.67	3.36133	...	...	0.22275
7.00	3.36133	4.85314	1.99995	
8.00	3.36133	4.91317	1.99999	0.18564
9.00	3.36133	4.95985	2.00000	
10.00	3.36133	4.99720	2.00000	0.14858
20.00	3.36133	5.16527	2.00000	0.07341
50.00	3.36133	5.26611	2.00000	
100.00	3.36133	5.29972	2.00000	
$\infty$	3.36133	5.33333	2.00000	0.00000

#### X4. SHEAR MODULUS

X4.1 Assuming the tested material is isotropic, the elastic deflection of a prismatic shear modulus specimen under a single-center point load (Fig. X2.1(c)) is (from Gromala (3)):

$$\Delta = \frac{P\ell^3}{48E_{sf}I} + \frac{P\ell}{4GKA} \quad (X4.1)$$

X4.2 All parameters in Eq X4.1 are specified in Appendix X1 and are self-explanatory with the exception of the shear coefficient,  $K$ . The shear coefficient is a reciprocal of so-called shape factor, which is a dimensionless quantity dependent on the cross-sectional dimensions of the specimen. These shape factors for various specimen cross-sections are found in *Roark's Formulas for Stress and Strain* (1)<sup>5</sup> and other literature, or can be derived using the second Castigliano's theorem. Most common shapes of lumber and wood-based materials are rectangular and circular, for which the shear coefficients have the following magnitudes (1):<sup>5</sup>

$$K = \frac{9}{10} \text{ (circular section)} \quad (X4.2)$$

$$K = \frac{5}{6} \text{ (rectangular section)}$$

X4.3 Often the relationship between deflection and elastic constants is simplified by ignoring the shear contribution, or the second term in Eq X4.1. The resulting elastic constant is then called the "apparent" modulus of elasticity,  $E_{app}$ :

$$\Delta = \frac{P\ell^3}{48E_{app}I} \quad (X4.3)$$

X4.4 At the same deflection the apparent modulus of elasticity,  $E_{app}$ , can be expressed in terms of the shear-free modulus of elasticity,  $E_{sf}$ , and the shear modulus,  $G$ :

$$\frac{P\ell^3}{48E_{app}I} = \frac{P\ell^3}{48E_{sf}I} + \frac{P\ell}{4GKA} \quad (X4.4)$$

X4.5 For a rectangular section of width  $b$  and depth  $d$ , Eq X4.4 reduces to:

<sup>5</sup> Available from page 210 of *Roark's Formulas for Stress and Strain* (1).

TABLE X4.1 Shear Modulus Formulas

Line	Mechanical Property	Formula
1	Apparent modulus of elasticity, $E_{app}$ (center point loading)	$\frac{P\ell^3}{48I\Delta}$
2	Shear modulus, $G$ (rectangular section)	$\frac{6}{5K_1}$
3	Shear modulus, $G$ (circular section)	$\frac{5}{6K_1}$

$$\frac{\ell^2}{E_{app}d^2} = \frac{\ell^2}{E_{sf}d^2} + \frac{1}{KG} \quad (X4.5)$$

X4.6 Multiplying both sides of Eq X4.5 by  $(d/\ell)^2$  yields:

$$\frac{1}{E_{app}} = \frac{1}{E_{sf}} + \frac{1}{KG} \left(\frac{d}{\ell}\right)^2 \quad (X4.6)$$

X4.6.1 Eq X4.6 can be expressed as a linear function by substituting  $y = 1/E_{app}$  and  $x = (d/\ell)^2$ . In the resulting line

equation,  $y = 1/E_{sf} + K_1x$ , the slope of the line connecting multiple data points is  $K_1 = 1/KG$  and  $y$ -intercept is the reciprocal of the shear-free modulus of elasticity,  $E_{sf}$ .

X4.7 For a circular section of diameter  $D$ , Eq X4.4 reduces to:

$$\frac{1}{E_{app}} = \frac{1}{E_{sf}} + \frac{3}{4KG} \left(\frac{D}{\ell}\right)^2 \quad (X4.7)$$

Therefore,  $K_1 = 3/4KG$ .

X4.8 Using plots for  $1/E_{app}$  versus  $(d/\ell)^2$  for rectangular sections or  $(D/\ell)^2$  for circular sections and substituting  $K$  from Eq X4.2, shear modulus,  $G$ , can be expressed in terms of the slope  $K_1$  as follows (see also Table X4.1):

$$G = \frac{5}{6K_1} \text{ (circular section)} \quad (X4.8)$$

$$G = \frac{6}{5K_1} \text{ (rectangular section)}$$

X4.9 Determination of shear modulus for other shear modulus specimen cross sections must start at Eq X4.4, substituting appropriate values for  $I$ ,  $A$ , and  $K$ .

X5. COMMENTARY

X5.1 Flexure Apparatus (Section 7)

X5.1.1 In the first edition of the standard, in 1924, the flexure test guidelines for timbers required third-point loading over a span length of 15 ft (4.57 m). Span-depth ratios between 11 and 15 were recommended for use whenever possible. Center-point loading was not recommended for flexure specimens over 4 in. in depth with the span-depth ratio of 15 or less.

X5.1.2 A diagrammatic sketch of the 1924 test setup is shown in Fig. X5.1. The procedure required that the supporting

knife-edges be preferably of the half-rocker type, and so placed to rock outward. To prevent accident or damage from their being thrust suddenly outward on failure of the specimen, they were tied together by means of a slack chain or cable. The load was applied through knife-edges rigidly attached to an auxiliary beam, which in turn was hinged by a knife-edge. Metal bearing plates and rollers were used between each bearing block and its corresponding knife-edge. If the supporting

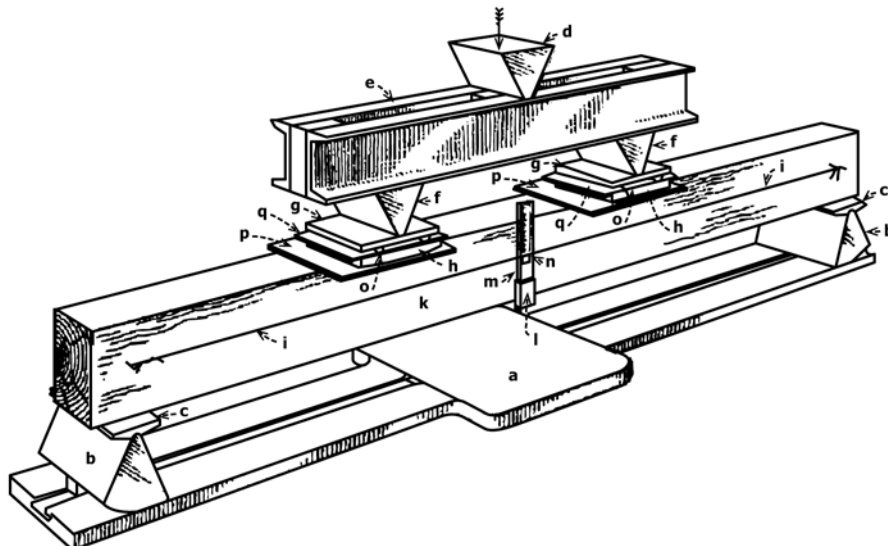

FIG. X5.1 Diagrammatic Sketch Showing Method of Conducting Static Bending Test of Structural Sizes of Timber (from ASTM D198-24)

knife-edges were of full-rocker type rather than the half-rocker type, rollers were placed under one loading knife-edge only.

X5.1.3 In 1967, the flexure test description was substantially revised. Specimen length, span-depth ratio, and location of load points were determined depending on the purpose of the test, allowing more freedom in test design. However, center-point loading was no longer mentioned. *Description of support apparatus (7.2)* allowed a choice between rocker-type reactions and fixed knife-edge reactions in conjunction with bearing plates supported by rollers. *Description of load apparatus (7.3)* required rollers in conjunction with one load bearing block (Fig. X5.2). The test setup described in Section 7 thus represented completely constrained but statically determinate condition with two rolling supports, one rolling load block, and one pinned load block. This setup reflected the testing practice on machines with load measuring devices built in the support table (for example, Tinius-Olsen machines).

X5.1.4 Most modern machines have load measuring devices (load cells) built in the machine head, that is, located above the specimen. In this case, it is desirable to reverse the location of the pin in the load evener with one of the reaction rollers, so both load blocks are used in conjunction with rollers (or sliders) allowing unrestrained displacement of the load evener along the specimen. Unrestrained horizontal sliding of the load evener is especially critical for tests on specimens experiencing large deflections (for example, long-span or low-stiffness specimens): if one of the load blocks were pinned, the contraction of the top specimen fibers could place an eccentric load on the load cell. Apart from biased load readings and potential damage to the load cell, such movement may cause slippage of the pinned load block along the specimen producing saw-like load-deflection curve. It is the opinion of the committee that the example of the test setup in Fig. 1 in current edition represents the most common modern practice and is recommended for test machines with load measuring devices built in the load head.

X5.1.5 *Reaction Bearing Plates(7.2.1)*—The size of the bearing plates may vary with the size and shape of the

specimen being tested. The minimum length should be selected to prevent bearing failures. In the past, for rectangular specimens as large as 12 in. (305 mm) deep by 6 in. (152 mm) wide, the recommended size of bearing plate was ½ in. (13 mm) thick by 6 in. (152 mm) lengthwise and extending entirely across the width of the specimen.

X5.1.6 *Reaction Supports (7.2.2) and Load Bearing Blocks (7.3.1)*—To restrict horizontal translation of the flexure specimen in case of two-point loading, one of the supports or load bearing blocks should be constrained from horizontal sliding or rolling (that is, should be “pinned”) to keep the specimen statically determinate.

X5.1.7 *Load Points (7.3.2)*—One of the objectives of two-point loading is to subject the portion of the specimen between load points to a uniform bending moment, free of shear, and with comparatively small loads at the load points. For example, to develop a moment of similar magnitude, loads applied at one-third span length from reactions would be less than that applied at one-fourth span length from reaction. When loads are applied at the one-third points, the moment distribution of the specimen simulates that for loads uniformly distributed across the span to develop a moment of similar magnitude. If loads are applied at the outer one-fourth points of the span, the maximum moment and shear are the same as the maximum moment and shear for the same total load uniformly distributed across the span. Center-point loading is not recommended for destructive tests on long-span specimens with large cross-sections. However, it is acceptable for determination of bending stiffness properties and shear strength.

X5.1.8 *Evaluation of Shear Properties (7.3.2.3)*—For evaluation of shear properties, it is desirable to minimize shear-free span or minimize span-depth ratio of the specimen, or both. The clear distance between the reaction bearing plate and load bearing blocks influences the shear stress distribution in the specimen. It will normally be at least two times the specimen depth. For the two-point loading setup, the clear distance between load bearing blocks will normally not exceed 6 in. (152 mm) (see Fig. X5.3). The clear distance of at least two

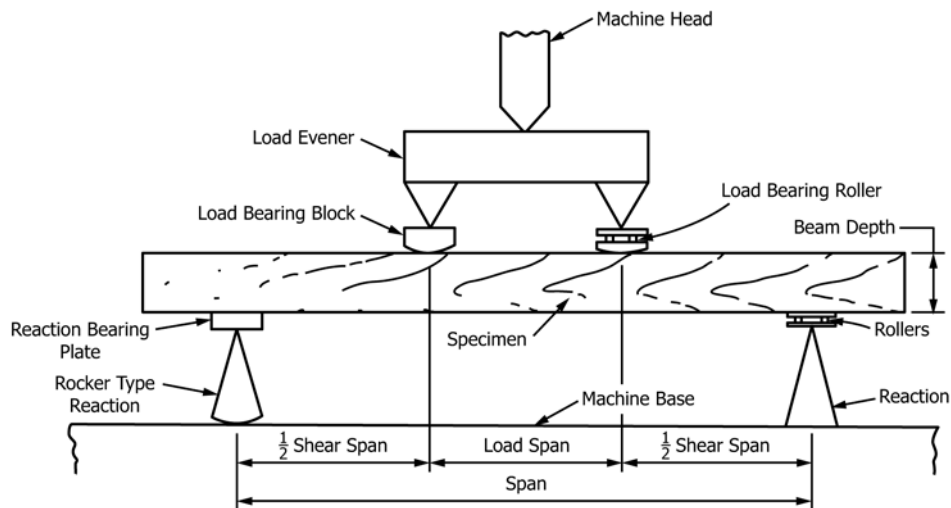

FIG. X5.2 Flexure Method (from ASTM D198-67)



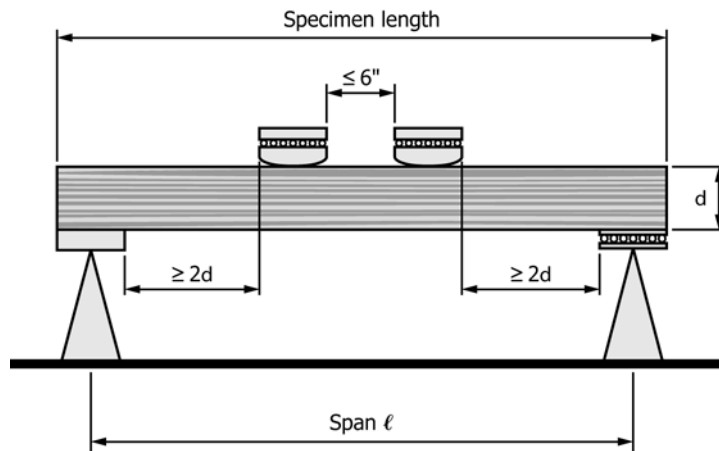

FIG. X5.3 Spacing of Load Bearing Blocks and Specimen Length for Evaluation of Shear Properties

times the specimen depth is intended to limit the influence of compression perpendicular to grain stress on shear stress distribution. For short deep specimens with large cross sections, two-point loading is preferred to spread the applied load and avoid crushing of specimen under the load block and also to reduce the effect of the load block on contraction of the contact surface of the specimen.

#### X5.2 Deflection-Measuring Apparatus (7.4)

X5.2.1 The guidance provided in this section assumes that the structural product is a linear elastic and homogenous material. In general, it is appropriate to make this assumption for sawn lumber and most wood-based materials. Provided a standard loading configuration, such as third-point loading, is followed test results are comparable and repeatable.

X5.2.2 The apparatus used to support the specimen, apply the load, and measure the deflection will affect the deflection of the specimen under a specified load. Some materials or materials under certain conditions may be more or less sensitive to departures from these reference test configurations.

X5.2.3 Where the loading configuration cannot be maintained, conversion factors such as those in Practice D2915 may be used, but it should be recognized that use of such equations might introduce bias and errors. Developments of such conversion factors are beyond the scope of this standard. Product specifications will generally provide descriptions of the standard loading configuration and acceptable adjustment procedures.

X5.2.4 *Shear-Free Modulus of Elasticity (7.4.1.2)*—Reference points for shear-free deflection measurements should be selected such that they avoid areas of stress concentration, but are set far enough apart so that the deflection can be accurately measured with the deflection device. It is recommended that the reference points be offset at least half of the specimen depth towards the mid-span away from the load points.

#### X5.2.5 Wire Deflectometer (7.4.2) and Yoke Deflectometer (7.4.3):

X5.2.5.1 The intent is not to limit the devices to those described. Other arrangements that meet the requirements of the General Clause are acceptable.

X5.2.5.2 Because the specimen deflections are measured relative to the deflectometer, the deflectometer spanning the two reference points should be sufficiently rigid or taut, in the case of a wire. Care should be taken to ensure that the deflectometer is not disturbed while the specimen is deflecting. Possible sources of erroneous results include the following: using a spring-loaded deflection measurement device where the spring force is high enough to cause the deflectometer to flex significantly as compared to the specimen deflection; and using a deflectometer that rubs against the side of the specimen as it deflects.

#### X5.2.6 Alternative Deflectometers (7.4.4):

X5.2.6.1 For long or unusual specimen configurations, it may not be practical to follow one of the traditional methods (described in 7.4.2 and 7.4.3). Provided sufficient documentation is provided to demonstrate that the deflection measurements would be equivalent to that from a device meeting specifications in 7.4.1, the method should be acceptable. The note emphasizes that some judgment is required when selecting the samples for demonstrating equivalency.

X5.2.6.2 The intent of this section is to demonstrate equivalency of devices. It is not intended to permit an adjustment factor to be developed or used.

#### X5.2.7 Accuracy (7.4.5):

X5.2.7.1 When assessing the accuracy of a computer-based displacement recording system, the precision of the displacement transducer and the analog-to-digital (A-to-D) converter should be considered. See Practice E2309.

X5.2.7.2 The number of “significant figures” is the number of figures known with some degree of reliability plus one digit which is an estimate or approximation. It is convenient to use scientific notation when reporting results: for example,  $1.23 \times 10$  mm is the same as  $4.84 \times 10^{-1}$  in. (3 significant figures); similarly  $1.0 \times 10^{-3}$  in. would be the same as  $2.5 \times 10^{-2}$  mm (2 significant figures). When adding or subtracting, the result cannot be more accurate than the least accurate measurement: for example,  $110.2 - 1.34 = 108.86$  but report as 108.9. When multiplying or dividing, the result cannot have more significant figures than the least accurate measurement: for example,  $10.20 / 1.3 = 7.84615\dots$  but report as 7.8.

X5.2.7.3 (See 7.4.5) Because the deformations measured within the shear-free portion of the flexure specimen are only a fraction of that measured over the total span, more accurate devices are required. For shear-free deflection measurements, it may be desirable to use a quarter-point rather than a third-point loading scheme. When doing so, the consideration should be given to possible bearing failures and the effect of span on the specimen response.

### X5.3 Rules for Determination of Specimen Length (8.5)

X5.3.1 The length of a specimen is established depending on the purpose of the test and type of failure desired. For wood specimens of uniform rectangular cross section, the desired span length can be estimated using the  $a/d$  ratio if approximate values of modulus of rupture ( $S_R$ ) and shear strength ( $\tau_m$ ) are known. It is assumed that when  $a/d = S_R/4\tau_m$  the specimen is equally likely to fail in either shear or in flexure.

X5.3.2 The length of flexure specimens intended primarily for evaluation of shear strength should be such that the shear span is relatively short. For wood specimens, it is generally assumed that  $S_R$  is 10 times greater than  $\tau_m$ . Therefore, it is assumed that specimens with  $a/d$  near 2.5 would produce a high percentage of shear failures. Indeed, the ratio  $S_R/\tau_m$  depends on the lumber grade, type of material tested, and other variables. Often, tests on short-span specimens produce a number of failure modes other than shear. Statistical analysis and interpretation of test data is beyond the scope of these test methods. An example of guidance on interpreting of shear strength data can be found in Practice D3737, Appendix.

X5.3.3 The span length of specimens intended primarily for evaluation of flexural properties (bending strength and modulus of elasticity) should be such that the shear span is relatively long. Wood specimens of uniform rectangular cross section having  $a/d$  ratios from 4 to 6 are in this category. The  $a/d$  values should be somewhat greater than  $S_R/4\tau_m$  so that the specimens do not fail in shear but should not be so large that specimen deflections cause sizable thrust of reactions and thrust values need to be taken into account. A suggested range of  $a/h$  values is between approximately  $0.4 S_R/\tau_m$  and  $0.6 S_R/\tau_m$ . In this range, shear distortions affect the total deflection, so that flexural properties may be calculated by formulae provided in Appendix X2.

X5.3.4 The span length of specimens intended primarily for evaluation of only the deflection of specimen due to bending moment should be such that the shear span is long. Solid wood products of uniform rectangular cross section in this category have  $a/d$  ratios greater than 6. The shear stresses and distortions are assumed to be small so that they can be neglected; hence the  $a/d$  ratio is suggested to be greater than  $0.6 S_R/\tau_m$ .

### X5.4 Precision and Bias of the Flexure Test Method (Section 12)

X5.4.1 Precision indexes stated in Table 1 are based on data from 11 out of 16 participating laboratories found to be in statistical control and in general compliance with the standard requirements. Statistical analysis determined that data from the five excluded laboratories were out of statistical control. Further investigation of these excluded cases established non-

compliance to the standard requirements due to mechanical deficiencies of the test setup or deflection measurement apparatus, or both, (for example, supports or load heads lacked free pivoting movement in one or another direction, yoke was mounted too loose or too tight on the side of the specimen, contact between the displacement transducer and the screw was not secured, diameter of the load blocks was too small, etc.). Therefore, data from these laboratories were removed from the analysis, according to Practice E691.

X5.4.2 In this study, the apparent modulus of elasticity,  $E_{app}$ , measured in accordance with this test method is the reference, and therefore, there is no bias (Practice E177, 28.10, Ex. 10.1). However, there may be laboratory bias due to the laboratory's particular implementation of the method or internal procedures. Because certified reference materials are not available, interlaboratory testing should be employed (Practice E177, 20.4) to determine the laboratory bias.

X5.4.3 A laboratory, which follows good professional practices may be considered competent to use this test method; however, the real precision and bias of a laboratory can only be quantified through an ILS. While the precision indexes stated in Table 1 do not necessarily represent all of the laboratories involved in the ILS, they set an achievable target for any competent laboratory. The statistics are valid for the conditions indicated in Table 1 and can be recommended as a reference for future interlaboratory comparisons of test results obtained from the Flexure Test Method for  $E_{app}$ .

X5.4.4 The indexes of precision of the tested materials did not seem to depend on the level of the measured  $E_{app}$ ; therefore, the indexes based on analysis of the pooled data can be applied. Reproducibility limits, however, differed considerably between the edgewise and flatwise tests and, therefore, should be stated separately. One reason for higher variation of the flatwise test results between laboratories can be attributed to the relative error in the length measurement of the shorter test span. Twist in the test specimens is also believed to influence the flatwise test results more than those on the edge, as the distance between the yoke and the longitudinal axis of the specimen increases.  $E_{app}$  test results were generally more consistent when the deflection measurements were taken closer to the side face of the specimen. Higher consistency of results was observed in a laboratory that used yokes on both sides of the specimen. For further details, please refer to RR:D07-1005.<sup>3</sup>

### X5.5 Shear Modulus

X5.5.1 *Calculation* (Section 43)—The units for the X and Y axes in Fig. 17 were chosen for ease of plotting a line in the format of  $y = mx + b$ . Appendix X4 describes the methodology to convert the slope and intercept of this line to the appropriate elastic constants ( $E_{sf}$ ,  $E_{app}$ ,  $G$ ).

### X5.6 Speed of Testing

X5.6.1 The bending (9.3), compression (18.3 and 26.3), tension (34.3), and torsion (42.3) test speeds employed by these test methods were uniformly updated in 2009. For tests that measured only the peak strength, prior versions specified that the maximum load be achieved in “about” 10 min with a

mandatory range for individual specimens of between 5 and 20 min. Slower rates were required for the compression, tension, and torsion test methods when deformations were to be measured. The bending test method specifically stated that the load rate should be “...a constant rate to achieve maximum load in about 10 min, but maximum load should be reached in not less than 6 min nor more than 20 min. A constant rate of outer strain,  $\epsilon$ , of 0.0010 in./in. • min (0.001 mm/mm • min) will usually permit the tests of wood members to be completed in the prescribed time.” When measuring load-deformation data, both of the compression test methods specified that the load be applied at a constant rate of head motion such that the fiber strain was 0.001 in./in. • min  $\pm$  25 % (0.001 mm/mm • min). For measuring only compressive strength, the test was permitted to be conducted at a constant rate to achieve maximum load in about 10 min, but not less than 5 nor more than 20 min. The tension method used the same load rate as the compression test when measuring only strength. However, when measuring tension load-deformation data, a constant rate of head motion was required to create a fiber strain of 0.0006 in./in. • min  $\pm$  25 % (0.0006 mm/mm • min). The torsion test method stated that “For measuring torque-twist data, apply the load at a constant rate of head motion so that the angular detrusion of the outer fibers in the test section between gauge points is about 0.004 radian per inch of length (0.16 radian per meter of length) per minute  $\pm$  50 %. For measuring only shear strength, the torque may be applied at a constant rate of twist so that maximum torque is achieved in about 10 min but not less than 5 nor more than 20 min.”

X5.6.2 It has long been recognized that the strength of wood products is time dependent and will be sensitive to duration of load effects. Consequently, it is expected that such products will be sensitive to rate of loading at test load durations. To enable test results to be presented on a consistent basis, a target time to failure of “about” 10 min was historically employed in these test methods. Test results obtained using this basis were then typically normalized in the various performance standards from a 10 min test to a 10-year load duration using an adjustment factor of  $1/1.6$  based upon the Madison Curve.

X5.6.3 With the advent of full-size lumber and wood-based material testing, it was observed that the rate of loading effects

used to establish characteristic property values were inconsistent (4). With load rates that result in times to failure between 4 and 20 min, the rate of loading effect was also not found to be as pronounced as previously thought. These observations were confirmed in analysis performed by Karacabeyli and Barrett on rate of loading data found in the literature (5).

X5.6.4 Faster loading rates that result in average times to failure of in the order of 1 minute have been subsequently permitted in standards such as Test Methods D4761 to efficiently process the larger sample sizes required in structural lumber testing programs. These faster test speeds have also typically been paired with the same adjustment factors that have normally been applied to tests undertaken using a 10 min test duration (that is,  $1/1.6$  adjustments factors to convert to a 10-year load duration.)

X5.6.5 The test methods in this standard were uniformly updated to require the average time to maximum load of at least 4 min for each test series in an effort to update the provisions to reflect modern test equipment capabilities and bring these test methods into closer agreement with alternate methods such as Test Methods D4761. Based upon the work of Karacabeyli and Barrett (5), the difference between a 4 and 10 min average time to maximum load was judged to be negligible. Accordingly, it is intended that structural wood products tested with this method should continue to use the existing adjustment factors to convert test data from this standard to common load durations.

X5.6.6 As noted in X5.6.3 and X5.6.5, the justification for the higher rates of loading are based on observations of rate of loading effects in large data sets of common wood products. For product where the rate of loading effect is not clear or where the test set is too small to permit a loading or displacement rate to be selected that meets the time to maximum load specified, the historic load rates outlined in X5.6.1 should be used. With wood products that exhibit considerable variability, an average load rate that well exceeds the 4 min minimum average should be considered. With small test sets, the suggested strain rates provided in X5.6.1 can still be used as an initial estimate that should comply with the provisions of this standard for most wood products.

## REFERENCES

- (1) Young, W. C., *Roark's Formulas for Stress and Strain*, McGraw-Hill, 1989.
- (2) Trayer, G. W., and March, H. W., “The Torsion of Members Having Sections Common in Aircraft Construction,” *NACA Report No. 334*, National Advisory Committee for Aeronautics, 1930.
- (3) Gromala, D. S., “Determination of Modulus of Rigidity by ASTM D198 Flexural Methods,” *Journal of Testing and Evaluation*, Vol 13, No. 5, September 1985, pp. 352–355.
- (4) Shelley, B., “Testing machines: development, calibration, and comparative studies,” in proceeding of the *In-Grade Testing of Structural Lumber*, Forest Products Research Society, Madison, WI, 1989.
- (5) Karacabeyli, E., and Barrett, J.D., “Rate of Loading Effects on Strength of Lumber,” *Forest Products Journal*, Vol 43, No. 5, May 1993, pp. 28–36.

*ASTM International takes no position respecting the validity of any patent rights asserted in connection with any item mentioned in this standard. Users of this standard are expressly advised that determination of the validity of any such patent rights, and the risk of infringement of such rights, are entirely their own responsibility.*

*This standard is subject to revision at any time by the responsible technical committee and must be reviewed every five years and if not revised, either reapproved or withdrawn. Your comments are invited either for revision of this standard or for additional standards and should be addressed to ASTM International Headquarters. Your comments will receive careful consideration at a meeting of the responsible technical committee, which you may attend. If you feel that your comments have not received a fair hearing you should make your views known to the ASTM Committee on Standards, at the address shown below.*

*This standard is copyrighted by ASTM International, 100 Barr Harbor Drive, PO Box C700, West Conshohocken, PA 19428-2959, United States. Individual reprints (single or multiple copies) of this standard may be obtained by contacting ASTM at the above address or at 610-832-9585 (phone), 610-832-9555 (fax), or [service@astm.org](mailto:service@astm.org) (e-mail); or through the ASTM website ([www.astm.org](http://www.astm.org)). Permission rights to photocopy the standard may also be secured from the Copyright Clearance Center, 222 Rosewood Drive, Danvers, MA 01923, Tel: (978) 646-2600; <http://www.copyright.com/>*